



MI 3365

Application notes

Ver 1.1.1. Code No. 20 753 367

Distributor:

Manufacturer:
METREL d.o.o.
Ljubljanska cesta 77
1354 Horjul
Slovenia

web site: <http://www.metrel.si>
e-mail: metrel@metrel.si

© 2023 METREL

No part of this publication may be reproduced or utilized in any form or by any means without permission in writing from METREL

Introduction

With the introduction of new EN standards for Electrical equipment testing, alongside existing electrical devices arose the need to test additional types of electrical equipment. Since specific requirements apply to certain electrical devices, this document will show how such electrical equipment is properly electrically tested. For certain applications, the associated optional accessories will also be used for the purpose of testing.

Table of Contents

- 1. Mode 2 EV cables testing using A 1632 6
 - I. Mode 2 EV Cable testing (3-phase)..... 6
 - List of Applicable test & Limits 7
 - Visual inspection..... 8
 - Functional test 9
 - Continuity of protective conductor 11
 - Insulation resistance of the protective conductor to the neutral and phase conductor..... 14
 - Protective conductor current..... 16
 - Compliance with tripping current EV-RCD..... 18
 - Proximity Pilot resistor check (Optional) 20
 - Error test..... 22
 - II. Mode 2 EV Cable testing (1-phase)..... 25
 - List of Applicable test & Limits 25
 - Visual inspection..... 26
 - Functional test 27
 - Continuity of protective conductor 29
 - Insulation resistance of the protective conductor to the neutral and phase conductor..... 35
 - Protective conductor current..... 37
 - Compliance with tripping current EV-RCD..... 39
 - Proximity Pilot resistor check (Optional) 41
 - Error test..... 44
- 2. Mode 2 EV cables testing using A 1532 47
 - Mode 2 EV Cable testing (1-phase) 47
 - List of Applicable test & Limits 47
 - Visual inspection..... 48
 - Functional test 49
 - Continuity of protective conductor 51
 - Insulation resistance of the protective conductor to the neutral and phase conductor..... 59
 - Protective conductor current..... 61
 - Compliance with tripping current EV-RCD..... 63
 - Proximity Pilot resistor check (Optional) 65
 - Error test..... 68

- 3. Mode 3 EV cables testing using A 1832 70
 - Mode 3 EV Cable testing 70
 - List of Applicable test & Limits 70
 - Visual inspection..... 70
 - Continuity of protective conductor 72
 - Proximity Pilot resistor check (Input and Output)..... 73
 - Continuity of CP (Control pilot) wire..... 74
 - Continuity of live wires..... 76
 - Insulation resistance of the protective conductor to the neutral and phase conductors 77
- 4. Testing devices with floating inputs 79
 - General info about devices with floating inputs 79
 - List of Applicable test & Limits 80
 - Visual inspection..... 80
 - Continuity of protective conductor 82
 - Insulation resistance of the protective conductor to the neutral and phase conductor..... 83
 - Leakage current test..... 85
 - Functional inspection..... 90

1. Mode 2 EV cables testing using A 1632

eMobility Analyser is a multi-function, portable, battery or mains powered test adapter intended for safety and functional testing of EVSE and charging cables for EV's.

Available functions and features of eMobility Analyser relevant for these applications:

- Simulation of electrical vehicle's CP and PP circuits;
- Simulation of errors on CP circuit and input mains;
- Accessible Inputs/ Outputs for connection of safety testers;
- Diagnostic test for verification of proper operation of CP circuit;
- Monitoring of communication between charging station and EV;
- Bluetooth communication with Metrel safety testers.

I. Mode 2 EV Cable testing (3-phase)

Due to the steady growth of the number of electrical vehicles on public roads, there is a consequent growth of public and private charging stations. Charging stations and charging cables are subject to wear and aging due to frequent use and environmental influences. To avoid defects that are crucial for the safety of users, this equipment shall be regularly tested and inspected.

The following procedures are intended to identify defects in charging cables and the associated electrical system components that pose a risk to users.

After the appropriate electrical examination has been carried out and any defects found have been eliminated, the required safety for the user is restored.

When performing recurrent testing on EV cables the EN 50699 must be taken into account. For the periodic testing of certain electrical systems, additional requirements may be specified in statutory ordinances or regulations that must be observed.

During the periodic inspection, the generally recognized rules of technology that were valid at the time the electrical system or electrical equipment was installed must be taken into account.

According to EN 50699, the electrical safety, and conformation of further protective measures shall be evaluated, as well as the complete functionality of electrical equipment.

List of Applicable test & Limits

Measurements according to German guideline for E-Mobility		
Measurement	Measuring method	Limits
Visual Inspection		
Functional inspection		
Continuity of protective conductor	Low resistance measurement	$\leq 0.3 \Omega$ (with connecting cables up to 5 m in length) plus 0.1Ω per additional 7.5 m up to max. 1.0Ω
Insulation resistance of the protective conductor to the neutral and phase conductor	Insulation resistance measurement	$\geq 1.0 \text{ M}\Omega$ (secondary side)
Protective conductor current	Measurement with residual current clamp	$\leq 3,5 \text{ mA}$
Compliance with tripping current PRCD	Trip test PRCD	$I\Delta N_a < I\Delta N$
Proximity Pilot resistor check (Optional)		

Table 1_Applicable measurements

Switch CP STATE	Vehicle status	Result
Status A	Vehicle not connected (idle state)	Yes / No
Status B	Vehicle connected but not ready to charge.	Yes / No
Status C	Vehicle connected and ready for charging, charging area ventilation not required	Yes / No

Table 2_Applicable functional statuses

ERRORS	Applied to:	Test condition
L / L1op	INPUT	L/L1 conductor opened
L / L2op		L/L2 conductor opened
L / L3op		L/L3 conductor opened
Nop		N conductor opened
PEop		PE conductor opened
L ↻ PE		L/L1 and PE conductors crossed*
U _{EXT} (PE)		External voltage on PE (on input side)*
PEop	OUTPUT	PE opened / EVSE output should de-energize within 100 ms.
CPsh		CP - PE shorted / EVSE output should de-energize within 3 s.
▷sh		CP diode shorted / EVSE output should de-energize within 3 s.

Table 3_Applicable errors

Visual inspection

Scope of test:

The visual inspection shall take place to detect external defects and, if possible, to determine the qualification of the suitability of the equipment for the environment.



Figure 1_Visual inspection

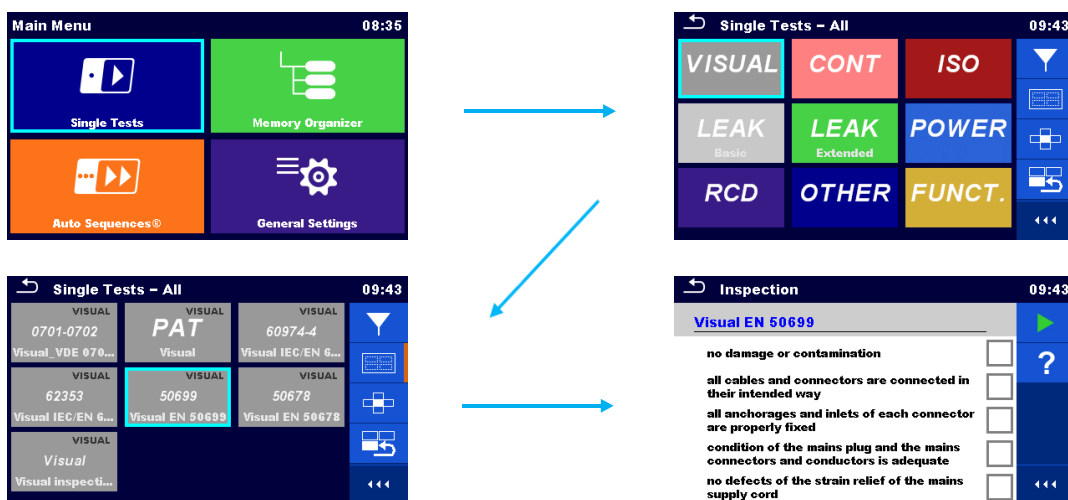

Figure 2_Visual inspection setup

Special attention shall be paid to the following:

- Check there is no damage or contamination,
- check that connectors are connected in their intended way,
- checking by hand to ensure that the anchorages and the inlets of each connector are properly fixed,
- check for defects in the mains lead cord grip,
- check for damage to the housing and protective cover that could give access to live or dangerous parts,
- check for signs of overload or overheating,
- check for signs of corrosion that impact protective measures and improper ageing,
- check for the usability of switches, control and setup equipment,
- check for the defect due to the bending of the cord.

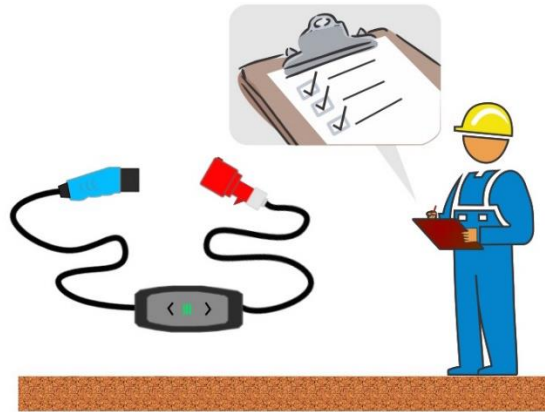

Figure 3_Visual inspection

Functional test

Scope of test:

Functional test of a Mode 2 EV cable is important to ensure that the cable operates properly and safely when charging an electric vehicle and help assess the overall condition and functionality of the Mode 2 EV cable.

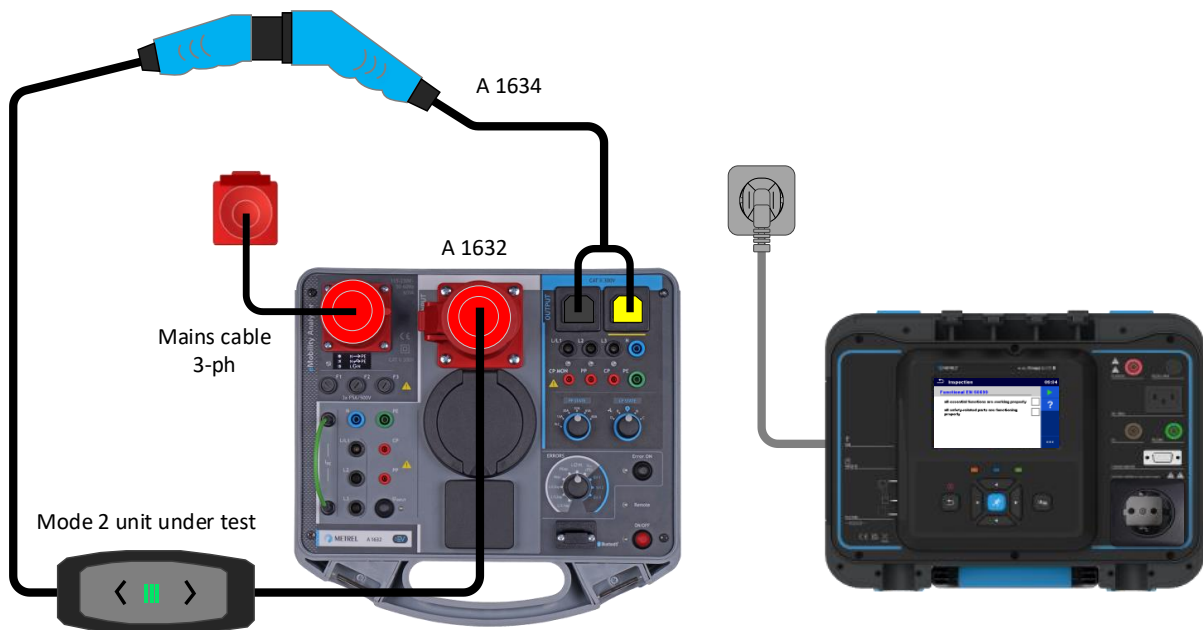

Figure 4_Mode 2 cable connection

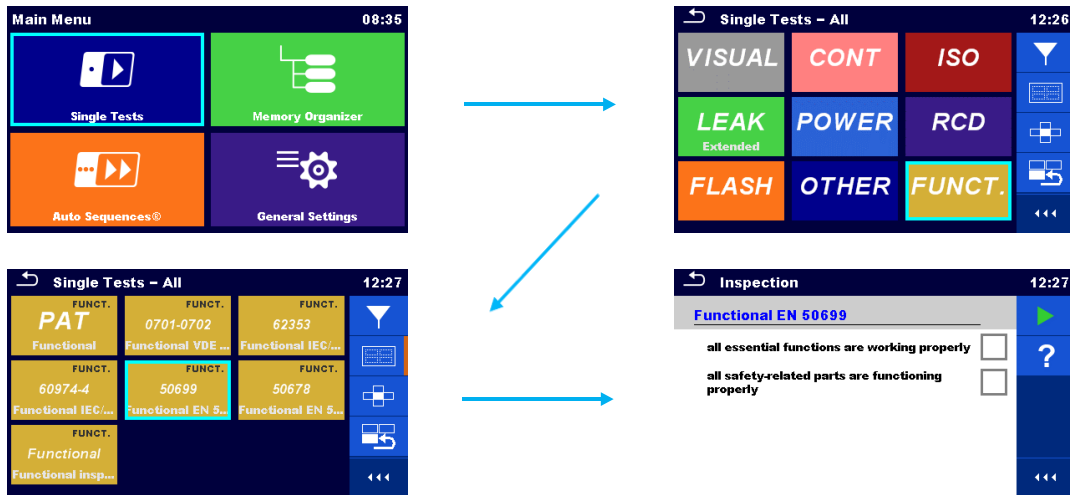

Figure 5_Functional inspection setup

Measurement procedure (EV stations with ventilations are mostly obsolete):

- Connect the charging cable to the eMobility Analyser (A 1632) (see Figure 4_Mode 2 cable connection).
- Follow the test procedure from bellow table, Table 4_Vehicle status.
- Check the response of the tested charging cable.

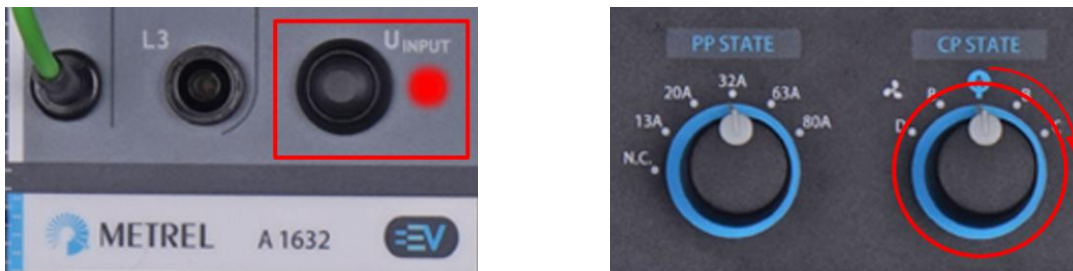

Figure 6_A 1632 keys and switches

*Switching between steps shall be performed dynamically from A → C.
 Delay between switching depends on the design of the EVSE.

Step	Key UINPUT	Switch CP STATE *	Vehicle status	Mode 2 cable condition	Result
1.	UINPUT = On	Not connected Status A	Vehicle not connected (idle state)	Observe manufacturer information for proper operation.	Yes / No
2.	UINPUT = On	Connected Status B	Vehicle connected but not ready to charge.	Observe manufacturer information for proper operation.	Yes / No
3.	UINPUT = On	Charging Status C	Vehicle connected and ready for charging, charging area ventilation not required	Observe manufacturer information for proper operation.	Yes / No

Turn off the UINPUT key, set switch CP state to Status A. Proceed to next step.

Table 4_Vehicle status

Once confirmed that the Mode 2 cable can be set to status C and it is properly operating, proceed with electrical safety testing.

Continuity of protective conductor

Scope of test:

With the low resistance measurement, the confirmation of the effectiveness of the protective bonding to all accessible conductive parts connected for safety reasons to protective earth is evaluated.

The measurement is performed using the MI 3365 & A 1632. The subject of evaluation is the PE conductor, between the input and the output terminal and/or all accessible earthed parts if applicable.

Some Mode 2 cables should be set to the charging position to evaluate the PE conductor in the cable. Observe manufacturer information for proper operation.

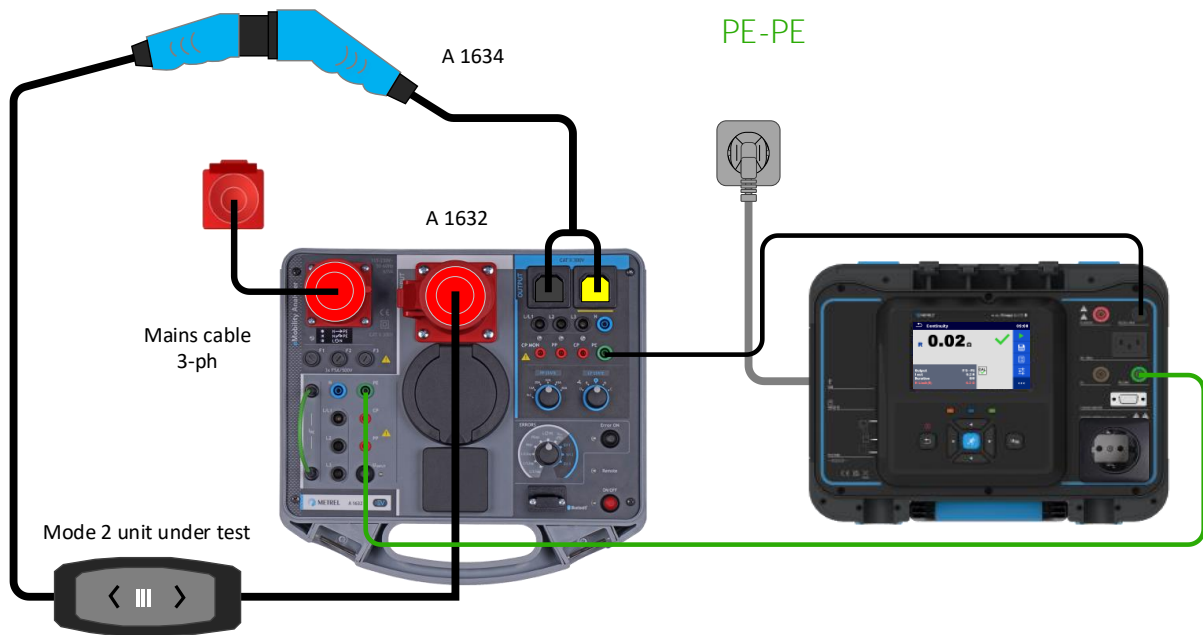

Figure 7_Continuity of protective earth

Test step	Test lead	A 1632	MI 3365
1	Black	PE Output	P/S
1	Green	PE Input	PE

Table 5_Test leads setup

Notes!

- Cord must be folded during test! If the result is changing during the measurement this means that the test failed.
- In order to perform measurement accurately the resistance of test leads should be compensated prior to execution of the Continuity test.

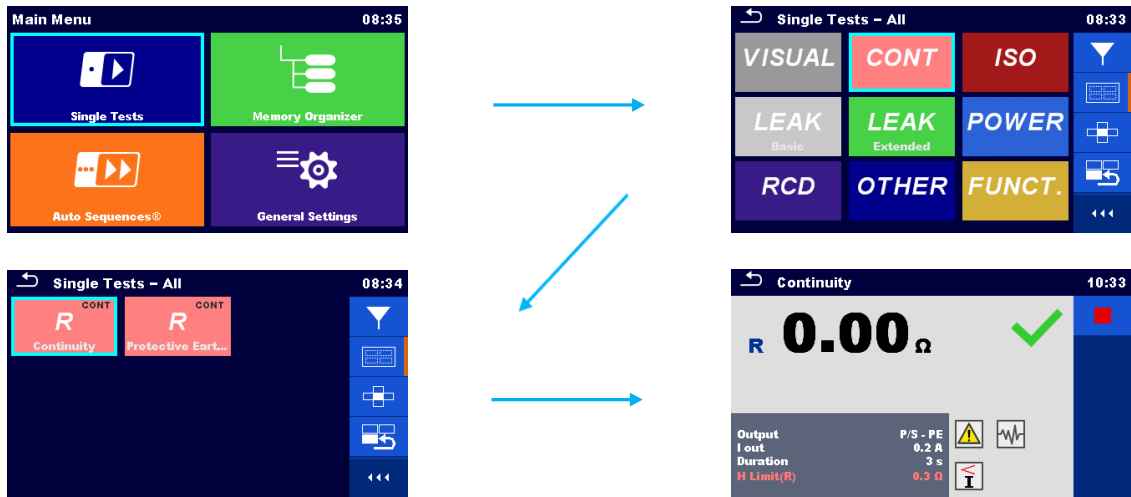

Figure 8_Earth continuity setup

Measuring function: R Continuity / Continuity

Output parameter: P/S – PE

I out: 0.2 A

Limit: $\leq 0.3 \Omega$ (with connecting cables up to 5 m in length) | plus 0.1Ω for each additional 7.5 m up to max. 1.0Ω

Measurement procedure

- Connect EV cable according to connection diagram,
- Set appropriate measurement parameters,
- Start the test.

Compensation of test leads

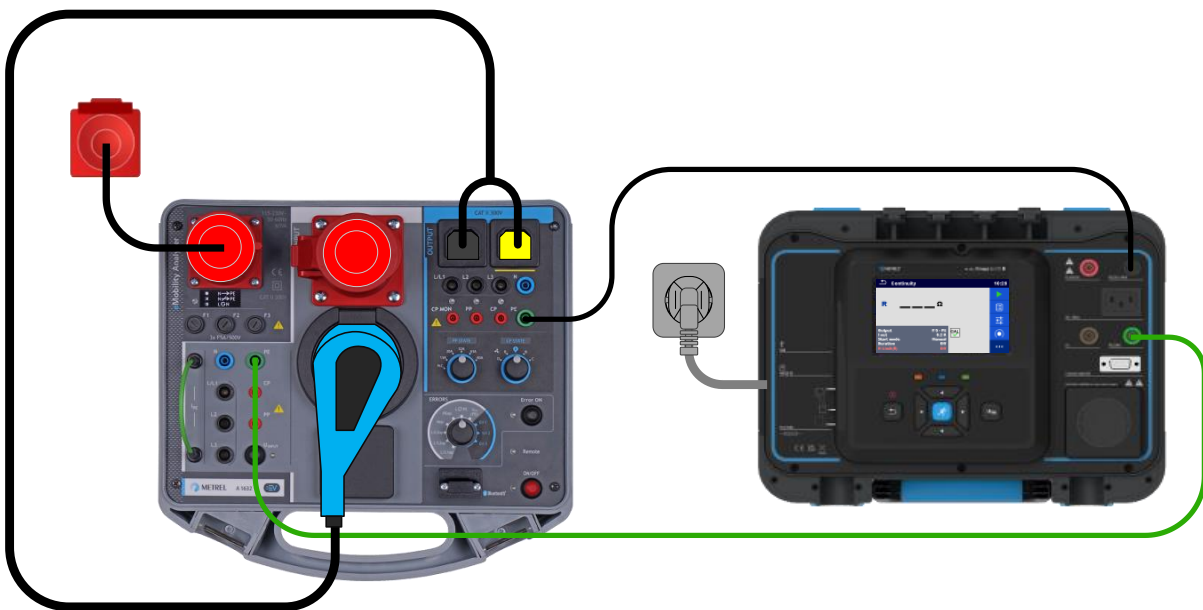

Figure 9_Test leads compensation

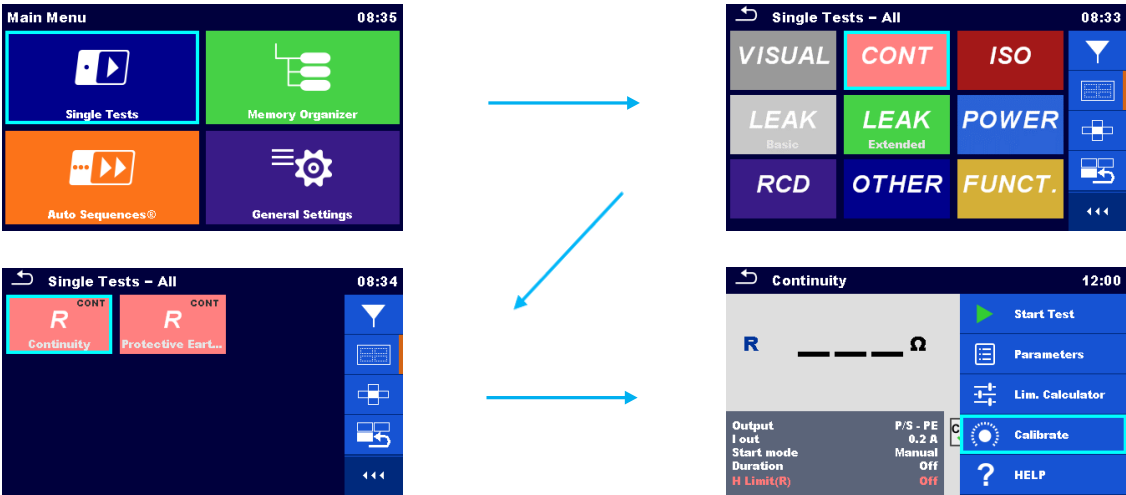

Figure 10_Calibration setup

Compensation procedure

- Connect test leads according to connection diagram,
- Select appropriate measurement,
- Start the calibration.

Insulation resistance of the protective conductor to the neutral and phase conductor

Scope of test:

With the insulation resistance measurement, the confirmation of the effectiveness of the insulation resistance between live parts and accessible conductive parts connected to protective earth is evaluated. This test discloses faults caused by pollution, moisture, deterioration of insulation material etc.

The measurement is performed using the MI 3365 & A 1632. The subject of evaluation is the insulation resistance between the PE conductor, and the live parts on the secondary side of the Mode 2 cable.

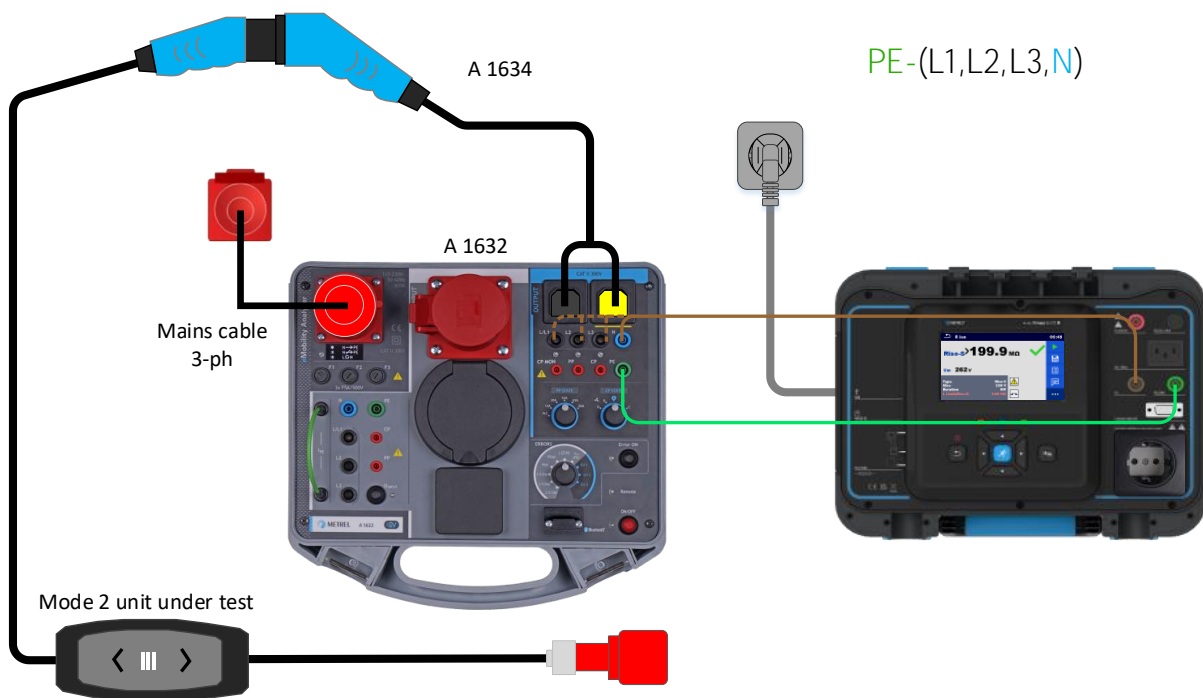

Figure 11_Insulation resistance

Test step	Test lead	A 1632	MI 3365
1 – 4	Green lead	PE	PE
1	Brown lead	N	LN
2	Brown lead	L3	LN
3	Brown lead	L2	LN
4	Brown lead	L1	LN

Table 6_Test leads setup

Note!

CEE cable shall be disconnected,

All live parts shall be subject to test. Reconnect LN/probe on A 1632 output side for evaluation of each live part separately.

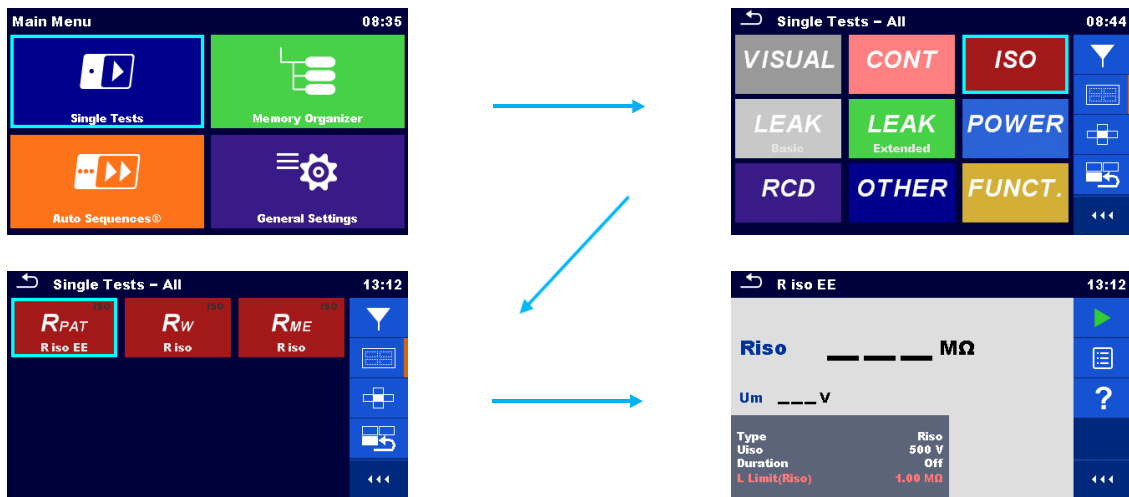

Figure 12_Insulation resistance setup

Measuring function: R_{PAT} / Riso EE

Output parameter: Riso

Uiso: 250 V, 500 V (Observe manufacturers information for appropriate test voltage)

Limit: $\geq 1,0 \text{ M}\Omega$ (secondary side)

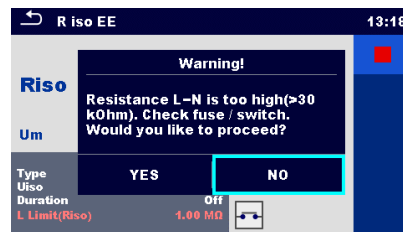

Figure 13_Insulation resistance warning

Insulation resistance pre-test is intended to warn the user for following possible causes:

- Device under test is not connected or switched on
- Input fuse of device under test is blown.

In this application the warning message is irrelevant as the test is made on the secondary side of the cable only.

Select **YES** to proceed with or **NO** to cancel measurement.

Note!

Warning message can be disabled under the settings, in the instruments setup menu! Load pretest (On/Off).

Protective conductor current

Scope of test:

With the PE leakage current measurement, compliance with the limits for the leakage current is evaluated. Using this method, the leakage current that would occur whilst the electrical equipment is in typical use is measured.

Device must be placed isolated against ground to prevent that a part of the leakage current would flow directly to ground instead through the PE conductor and ground.

Unearthed accessible conductive parts are not included in this test. They are considered as class II parts and are checked in the Touch Leakage test.

The measurement is performed using the MI 3365 + Optional current clamp (A 1579) & A 1632. The subject of evaluation is the insulation resistance and capacitance between the PE conductor, and the live parts of the Mode 2 cable.

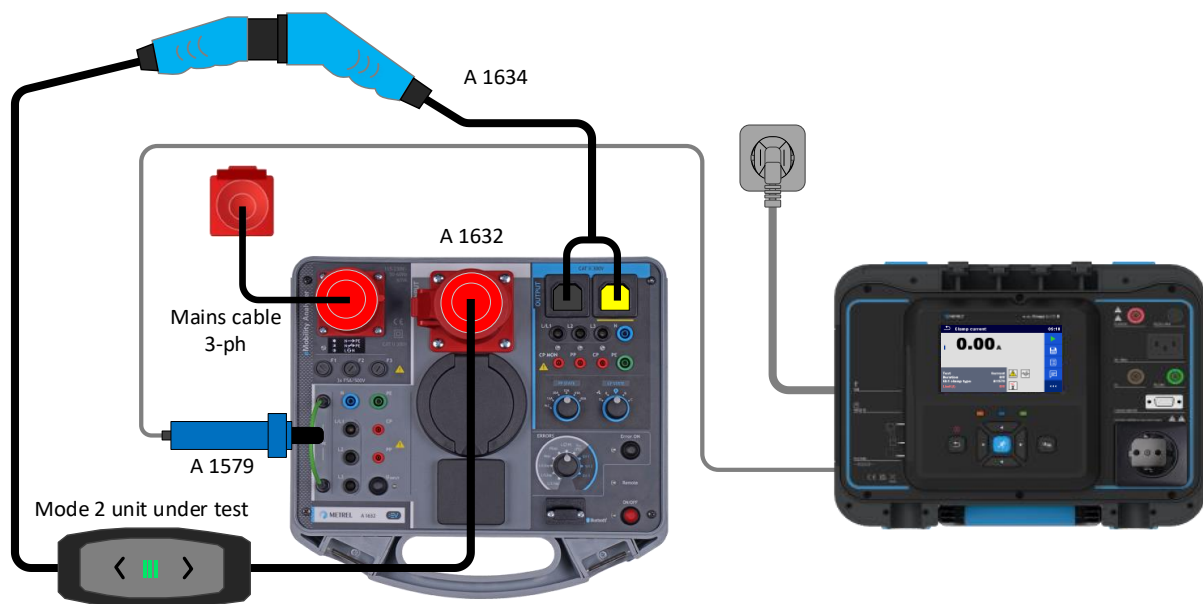

Figure 14_PE leakage current

Note!

Mode 2 cable shall be set to charging mode (Status C) using CP STATE switch of the A 1632, UINPUT key is set to On

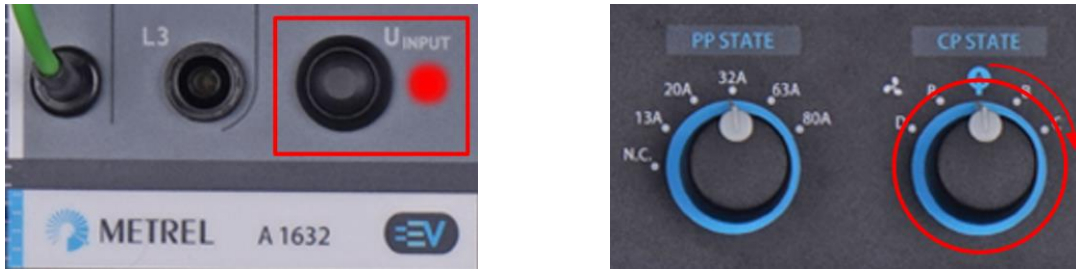

Figure 15_A 1632 keys and switches

*Switching between steps shall be performed dynamically from A → C.
Delay between switching depends on the design of the EVSE.

Step	Key U _{INPUT}	Switch CP STATE
1.	U _{INPUT} = On	Not connected Status A
2.	U _{INPUT} = On	Connected Status B
3.	U _{INPUT} = On	Charging Status C

Table 7_Mode 2 cable setup

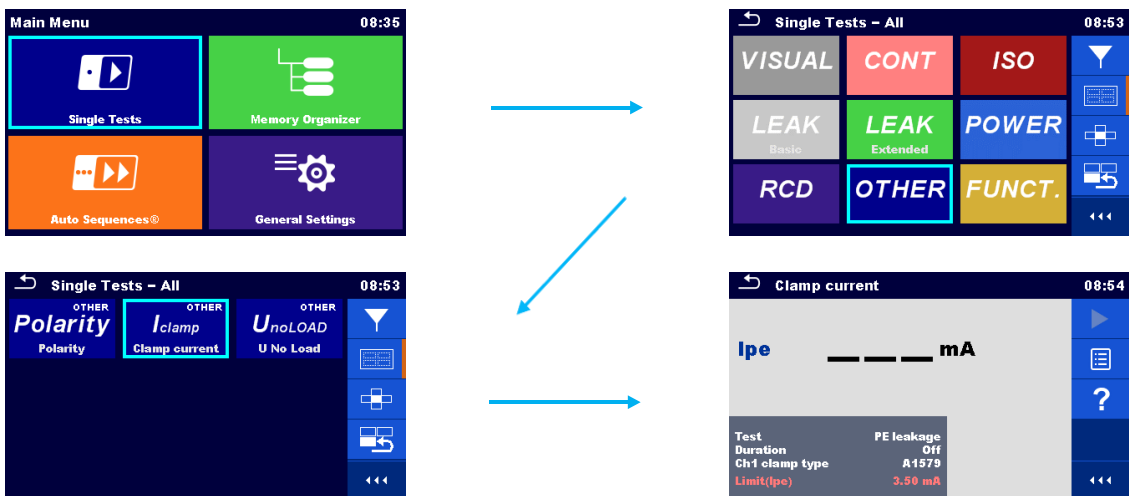

Figure 16_Current clamp setup

Measuring function: Iclamp / Clamp current

Clamp type: A 1579

Test: PE leakage

Limit: ≤ 3,5 mA

Compliance with tripping current EV-RCD

Scope of test:

With the EV-RCD test the effectiveness of the protective device is evaluated.

The EV-RCD in the Mode 2 cable provides an additional layer of electrical safety by monitoring the current flow and cutting off the power in the event of a fault or leakage. Testing the EV-RCD ensures that it is functioning correctly and can provide the necessary protection against electric shocks.

Remember to refer to the manufacturer's instructions or consult with a qualified electrician to ensure the correct testing procedures for EV-RCDs in Mode 2 EV cables, as they may vary depending on the specific model and regulations in your location.

According to EN 50699 and the German guideline for E-Mobility, the confirmation of the operation of further protective measures needs to be evaluated if the equipment under test includes such parts. This part is in our case EV-RCD.

Generally, it is enough to test only the ability of the EV-RCD to trip in case of fault. This can be evaluated on a single phase or all three phases separately.

1. Test setup (3-Phase evaluation all phases evaluated L1, L2, L3)

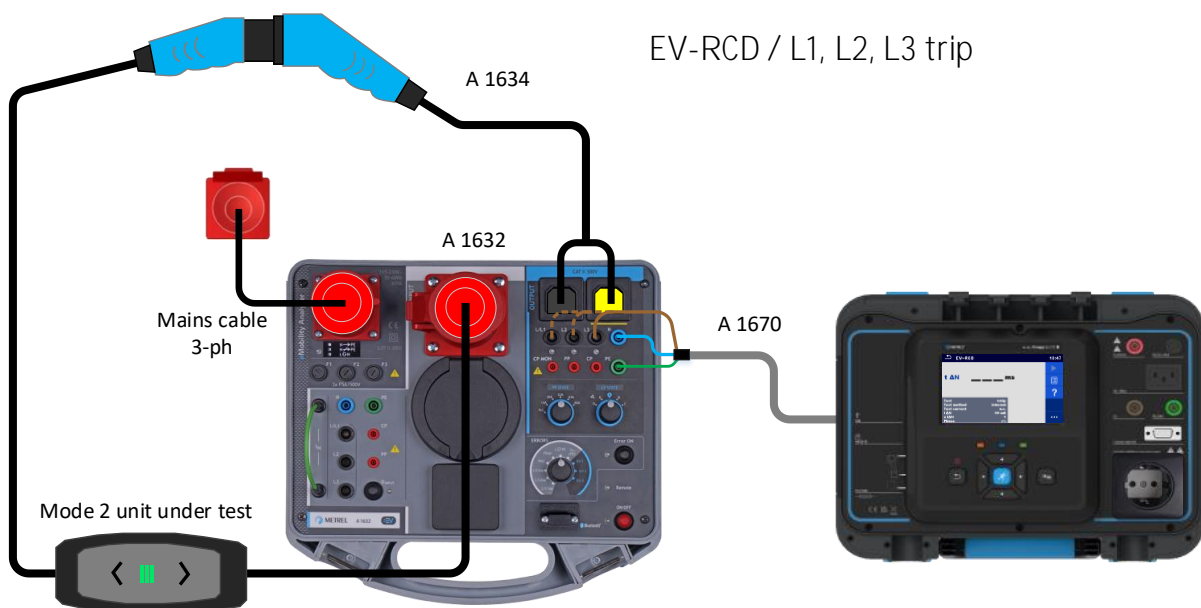

Figure 17_EV-RCD_Test method_external (all 3-phases evaluation)

Notes!

- Functionality of the EV-RCD shall be evaluated on all lines. Reconnect L/probe on A 1632 output side, for evaluation of EV-RCD trip-out for each line separately.
- Mode 2 cable shall be set to charging mode (Status C) using CP STATE switch of the A 1632.

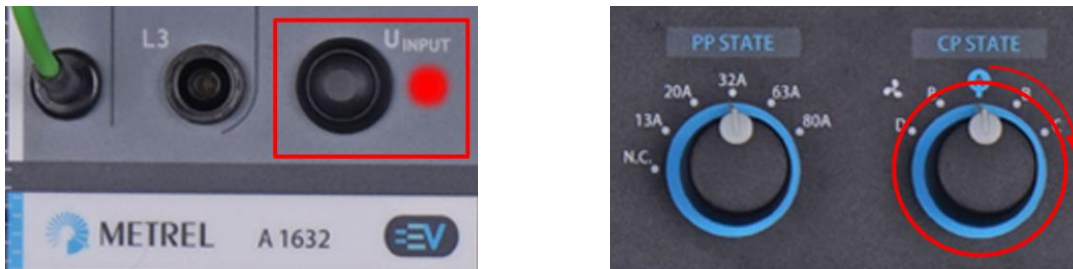

Figure 18_A 1632 keys and switches

The measurement is performed using the MI 3365 & A 1632. The subject of evaluation is EV-RCD of the Mode 2 cable.

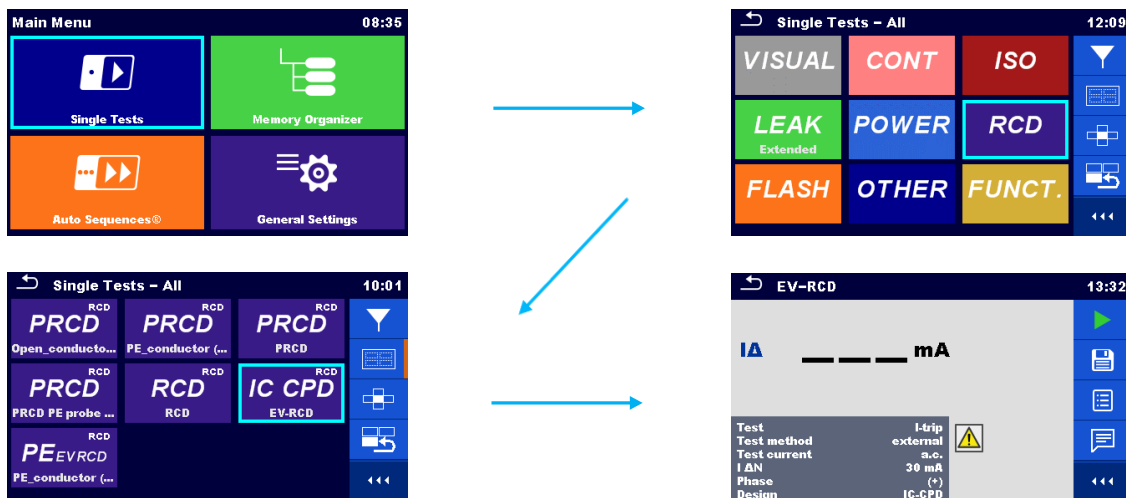

Figure 19_EV-RCD test setup

Measuring function: IC CPD / EV-RCD

Test method: internal / external

Test: t-trip / I-trip

Limit: $I\Delta N_a < I\Delta N$

Measurement procedure >> External (3-phase evaluation) <<

Key UINPUT	Switch CP STATE	Action	Action	Status	Status	Action
A 1632	A 1632	MI 3365	MI 3365	IC-CPD	MI 3365	MI 3365
UINPUT = On	Charging Status C	Accordingly connected via A 1670 cable	Start test 	EV RCD trip out	TURN ON MAINS VOLTAGE!	Connect instrument to mains!

Set switch CP state to Status A. Proceed to next step.

Table 8_EV-RCD test procedure

Notes!

- Repeat test procedure for different, EV-RCD settings,
- When testing is finished reconnect the test instrument to the mains.

Proximity Pilot resistor check (Optional)

Scope of test:

Charging speed is determined through the Proximity Pilot (PP). The PP is a resistor connected between the PP pin and the PE pin on the Type 2 connector or socket of a Mode 2 EV cable, a Mode 3 EVSE charging station or the EV. The coding of the resistor actually determines what cable is being used (the cross section) which further determines the maximum charging current and consequently charging speed.

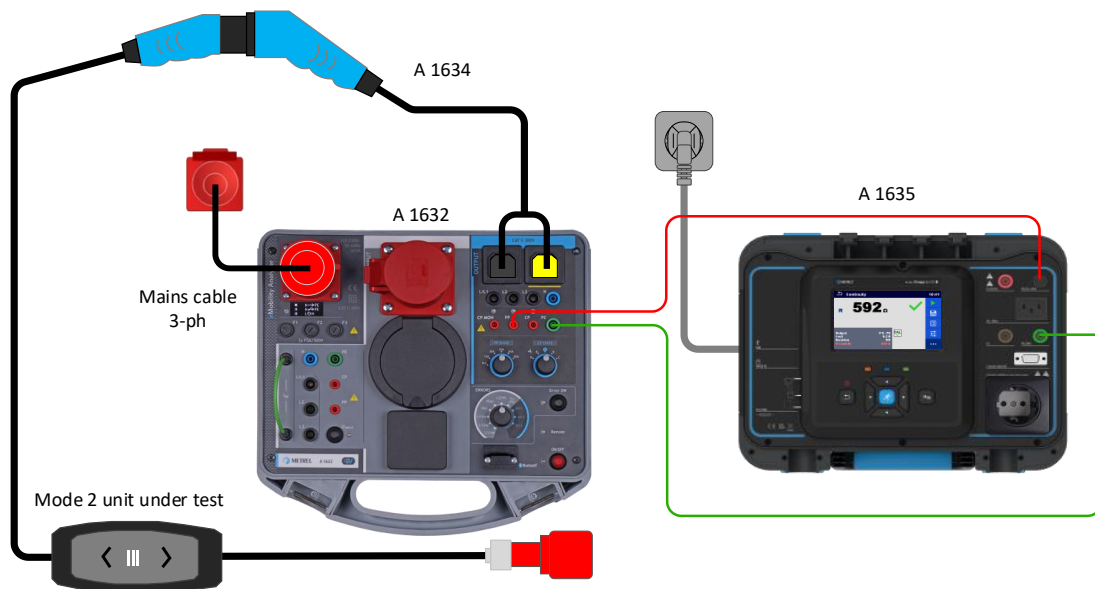

Figure 20_PP resistor_Test

Test lead	A 1632	MI 3365
Red	PP	P/S
Green	PE	PE

Table 9_Test leads setup

Note!

- Rotary switch on the A 1632 shall be set to (Status NC) using PP STATE switch. UINPUT is set to On.

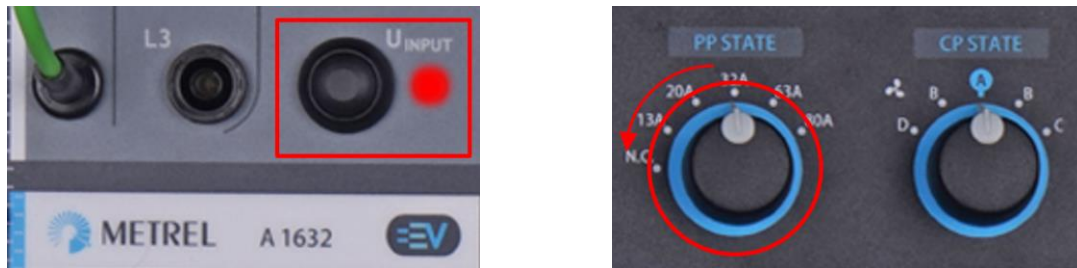

Figure 21_A 1632 keys and switches

The measurement is performed using the MI 3365 & A 1632. The subject of evaluation is the resistance of the PP resistor. on the secondary side of the Mode 2 cable.

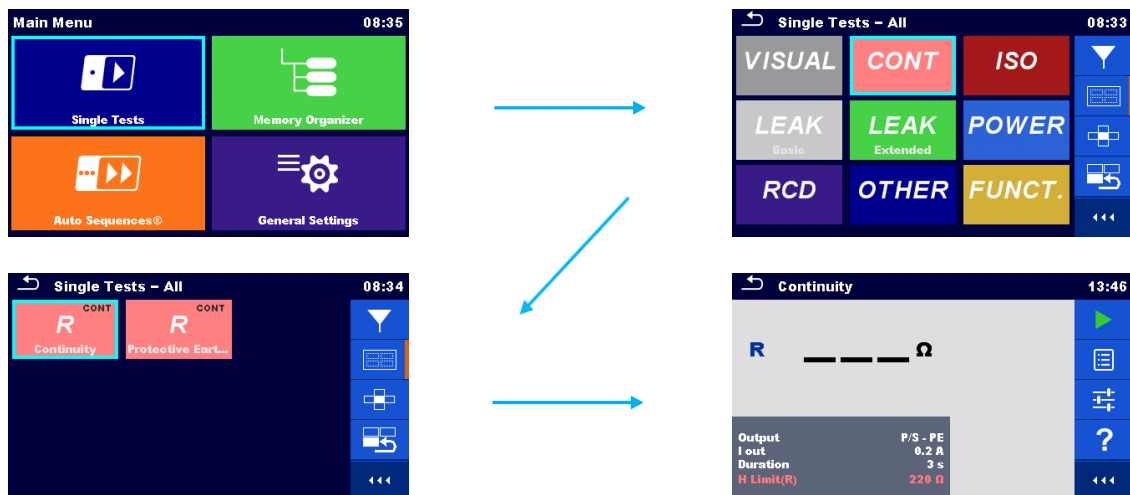

Figure 22_Resistance measurement setup

Measuring function: R Continuity / Continuity

Output parameter: P/S – PE

Iout: 0.2 A

Limits: The PP resistor can have the following values according to EN 61851-1:

- 1500 Ω \rightarrow 13 A Charging cable
- 680 Ω \rightarrow 20 A Charging cable
- 220 Ω \rightarrow 32 A Charging cable
- 100 Ω \rightarrow 63 A Charging cable

Error test

Scope of test:

Error test help assess the overall condition and functionality of the Mode 2 EV cable and diagnose the state of the Mode 2 cable protective circuit to react to possible errors present on the input and output side of the cable.

By simulating errors at the Mode 2 cable output, we ensure that in the event of a malfunction on the EV vehicle, the dangerous mains voltage is switched off at the cable output.

Therefore A 1632 has two options for simulating input mains errors:

- Simulation of connection of the charging cable to faulty mains,
- Simulation of a fault that occurs during operation.

By identifying these faults, you can take appropriate measures to repair or replace the cable, ensuring safe and reliable EV charging.



Figure 23_Functional inspection

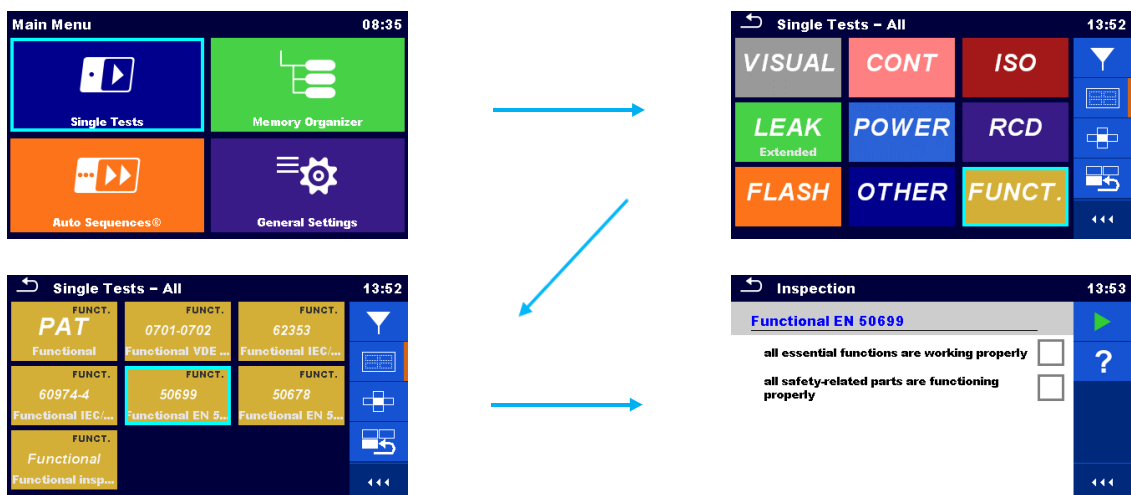

Figure 24_Functional inspection setup

Measurement procedure

Connect the charging cable to the A 1632 (see Figure 4_Mode 2 cable connection).

Set the Errors state rotary switch through all positions clockwise, starting from first position (L/L1op), follow the steps from bellow table.

Check the response of the tested charging cable.

Step	Key U _{INPUT}	Switch ERRORS	Switch CP STATE	Switch Error ON	Test condition
1.	U _{INPUT} = On	INPUT L / L1op	Charging Status C	Error ON/OFF = On	Mains voltage ERROR condition on the input of charging cable, L1 interrupted . Observe output LED's for status.
Turn off the Error ON/OFF key, set switch CP state to Status A. Proceed to next step.					
2.	U _{INPUT} = On	INPUT L / L2op	Charging Status C	Error ON/OFF = On	Mains voltage ERROR condition on the input of charging cable, L2 interrupted . Observe output LED's for status.
Turn off the Error ON/OFF key, set switch CP state to Status A. Proceed to next step.					
3.	U _{INPUT} = On	INPUT L / L3op	Charging Status C	Error ON/OFF = On	Mains voltage ERROR condition on the input of charging cable, L3 interrupted . Observe output LED's for status.
Turn off the Error ON/OFF key, set switch CP state to Status A. Proceed to next step.					
4.	U _{INPUT} = On	INPUT Nop	Charging Status C	Error ON/OFF = On	Mains voltage ERROR condition on the input of charging cable, N interrupted . Observe output LED's for status.
Turn off the Error ON/OFF key, set switch CP state to Status A. Proceed to next step.					
5.	U _{INPUT} = On	INPUT PEop	Charging Status C	Error ON/OFF = On	Mains voltage ERROR condition on the input of charging cable, PE interrupted . Observe manufacturer information for proper operation.
Turn off the Error ON/OFF key, set switch CP state to Status A. Proceed to next step.					
6.	U _{INPUT} = Off	INPUT L ↻ PE	Charging Status C	Error ON/OFF = On	Mains voltage ERROR condition on the input of charging cable, L_PE switched . The device shall not enter operation mode when set to status C. Observe manufacturer information for proper operation
Turn off the Error ON/OFF key, set switch CP state to Status A. Proceed to next step.					
7.	U _{INPUT} = Off	INPUT	Charging	Error ON/OFF = On	Mains voltage ERROR condition on the input of charging cable,

		U_{EXT} (PE)	Status C		External voltage on PE. The device shall not enter operation mode when set to status C. Observe manufacturer information for proper operation
Turn off the Error ON/OFF key, set switch CP state to Status A. Proceed to next step.					
8.	U_{INPUT} = On	OUTPUT CPsh	Charging Status C	Error ON/OFF = On	CP - PE shorted, EVSE output should de-energize within 3 s. Observe manufacturer information for proper operation
Turn off the Error ON/OFF key, set switch CP state to Status A. Proceed to next step.					
9.	U_{INPUT} = On	OUTPUT PEop	Charging Status C	Error ON/OFF = On	PE opened, EVSE output should de-energize within 100 ms. Observe manufacturer information for proper operation.
Turn off the Error ON/OFF key, set switch CP state to Status A. Proceed to next step.					
*10.	U_{INPUT} = On	OUTPUT →sh	Charging Status C	Error ON/OFF = On	CP diode shorted, EVSE output should de-energize within 3 s. Observe manufacturer information for proper operation
Turn off the Error ON/OFF key, set switch CP state to Status A. Error test finished.					

Table 10_Applicable error test

*CP diode shorted test can be performed optionally.

II. Mode 2 EV Cable testing (1-phase)

List of Applicable test & Limits

Measurements according to German guideline for E-Mobility		
Measurement	Measuring method	Limits
Visual Inspection		
Functional inspection		
Continuity of protective conductor	Low resistance measurement	$\leq 0.3 \Omega$ (with connecting cables up to 5 m in length) plus 0.1Ω per additional 7.5 m up to max. 1.0Ω
Insulation resistance of the protective conductor to the neutral and phase conductor	Insulation resistance measurement	$\geq 1.0 \text{ M}\Omega$ (secondary side)
Protective conductor current	Direct method	$\leq 3,5 \text{ mA}$
Compliance with tripping current PRCD	Trip test PRCD	$I\Delta N_a < I\Delta N$
Proximity Pilot resistor check (Optional)		

Table 11_Applicable measurements

Switch CP STATE	Vehicle status	Result
Status A	Vehicle not connected (idle state)	Yes / No
Status B	Vehicle connected but not ready to charge.	Yes / No
Status C	Vehicle connected and ready for charging, charging area ventilation not required	Yes / No

Table 12_Applicable functional statuses

ERRORS	Applied to:	Test condition
L / L1op	INPUT	L/L1 conductor opened
Nop		N conductor opened
PEop		PE conductor opened
L ↔ PE		L and PE conductors crossed*
U _{EXT} (PE)		External voltage on PE (on input side)*
PEop	OUTPUT	PE opened / EVSE output should de-energize within 100 ms.
CPsh		CP - PE shorted / EVSE output should de-energize within 3 s.
▷sh		CP diode shorted / EVSE output should de-energize within 3 s.

Table 13_Applicable errors

Visual inspection

Scope of test:

The visual inspection shall take place to detect external defects and, if possible, to determine the qualification of the suitability of the equipment for the environment.



Figure 25_Visual inspection

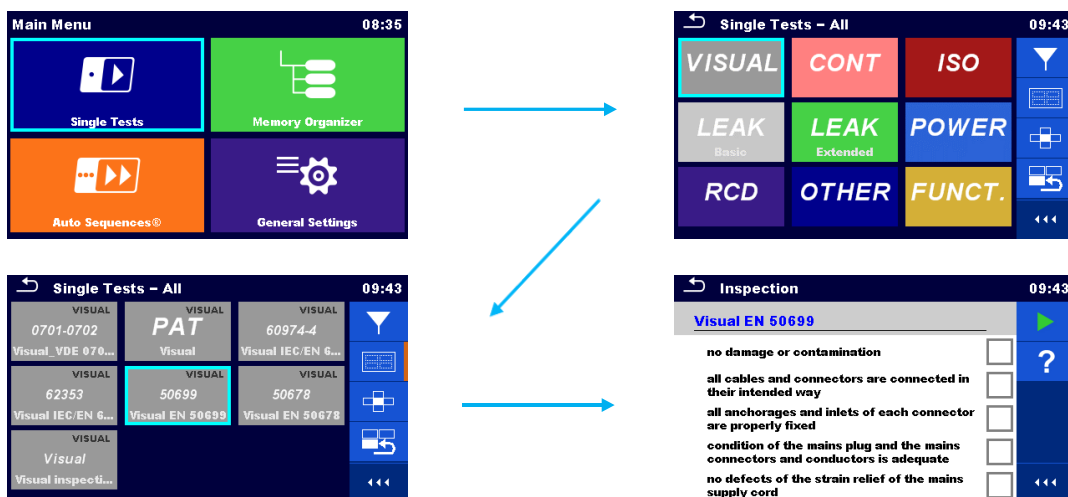

Figure 26_Visual inspection setup

Special attention shall be paid to the following:

- Check there is no damage or contamination,
- check that connectors are connected in their intended way,
- checking by hand to ensure that the anchorages and the inlets of each connector are properly fixed,
- check for defects in the mains lead cord grip,
- check for damage to the housing and protective cover that could give access to live or dangerous parts,
- check for signs of overload or overheating,
- check for signs of corrosion that impact protective measures and improper ageing,
- check for the usability of switches, control and setup equipment,
- check for the defect due to the bending of the cord.

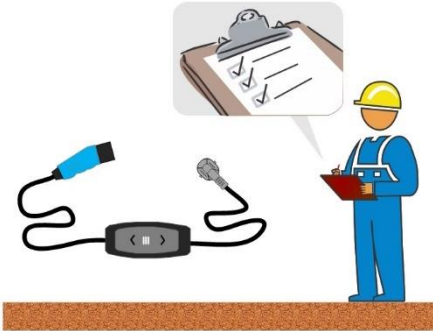

Figure 27_Visual inspection

Functional test

Scope of test:

Functional test of a Mode 2 EV cable is important to ensure that the cable operates properly and safely when charging an electric vehicle and help assess the overall condition and functionality of the Mode 2 EV cable.

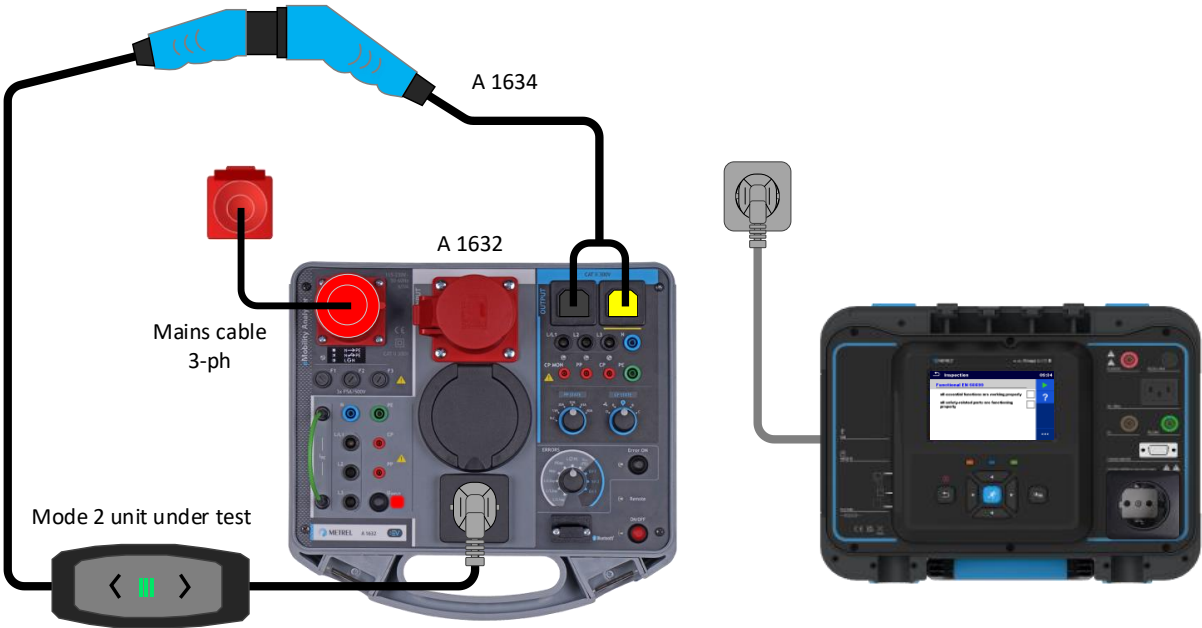

Figure 28_Mode 2 cable connection

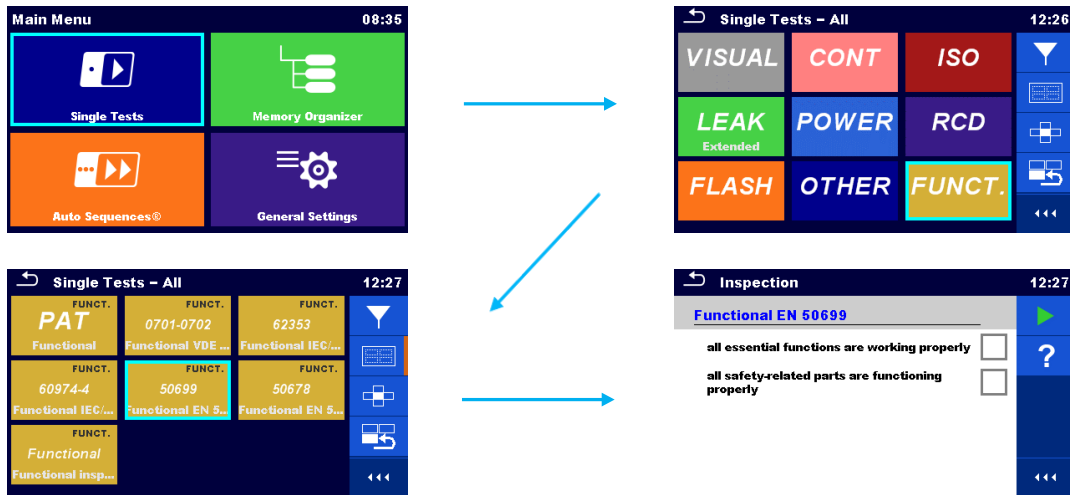

Figure 29_Functional inspection setup

Measurement procedure (EV stations with ventilations are mostly obsolete):

- Connect the charging cable to the eMobility Analyser (A 1632) (see Figure 4_Mode 2 cable connection).
- Follow the test procedure from bellow table, Table 4_Vehicle status.
- Check the response of the tested charging cable.

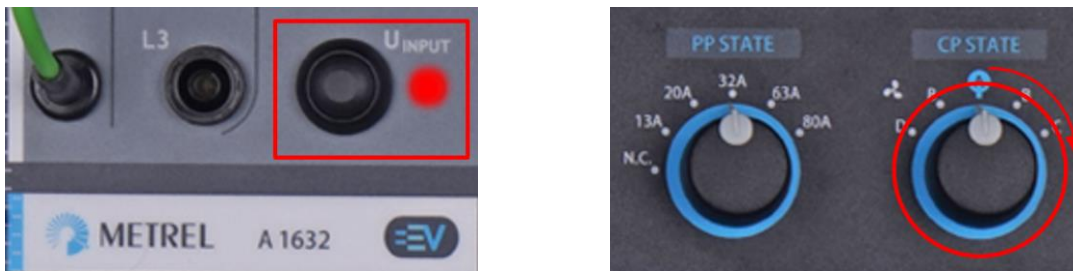

Figure 30_A 1632 keys and switches

*Switching between steps shall be performed dynamically from A → C.
 Delay between switching depends on the design of the EVSE.

Step	Key UINPUT	Switch CP STATE *	Vehicle status	Mode 2 cable condition	Result
1.	UINPUT = On	Not connected Status A	Vehicle not connected (idle state)	Observe manufacturer information for proper operation.	Yes / No
2.	UINPUT = On	Connected Status B	Vehicle connected but not ready to charge.	Observe manufacturer information for proper operation.	Yes / No
3.	UINPUT = On	Charging Status C	Vehicle connected and ready for charging, charging area ventilation not required	Observe manufacturer information for proper operation.	Yes / No

Turn off the UINPUT key, set switch CP state to Status A. Proceed to next step.

Table 14_Vehicle status

Once confirmed that the Mode 2 cable can be set to status C and it is properly operating, proceed with electrical safety testing.

Continuity of protective conductor

Scope of test:

With the low resistance measurement, the confirmation of the effectiveness of the protective bonding to all accessible conductive parts connected for safety reasons to protective earth is evaluated.

The measurement is performed using the MI 3365 & A 1632. The subject of evaluation is the PE conductor, between the input and the output terminal and/or all accessible earthed parts if applicable.

Some Mode 2 cables should be set to the charging position to evaluate the PE conductor in the cable. Observe manufacturer information for proper operation. Therefore, there are two different test setups applicable:

1. Test setup (EV not set to charging status)

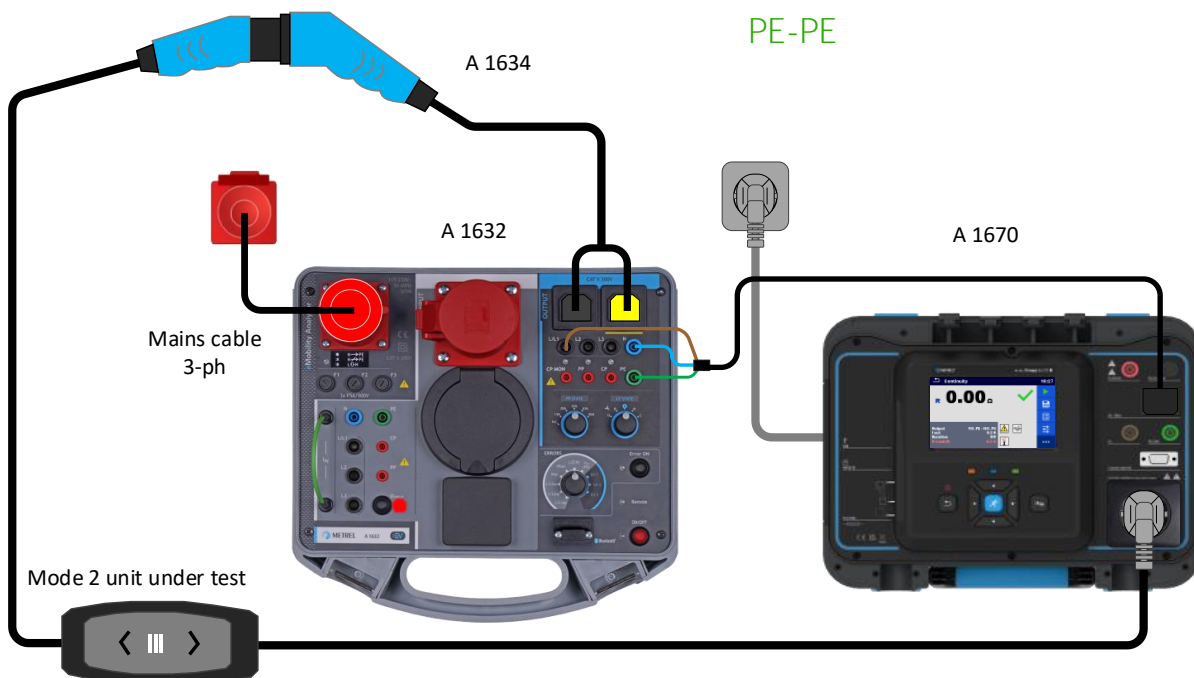

Figure 31_Continuity of protective earth

Test step	Test lead	A 1632	MI 3365
1	A 1670	PE	IEC/PRCD

1	A 1670	N	IEC/PRCD
1	A 1670	L1	IEC/PRCD

Table 15_Test leads setup

Notes!

- Cord must be folded during test! If the result is changing during the measurement this means that the test failed.
- In order to perform measurement accurately the resistance of test leads should be compensated prior to execution of the Continuity test.

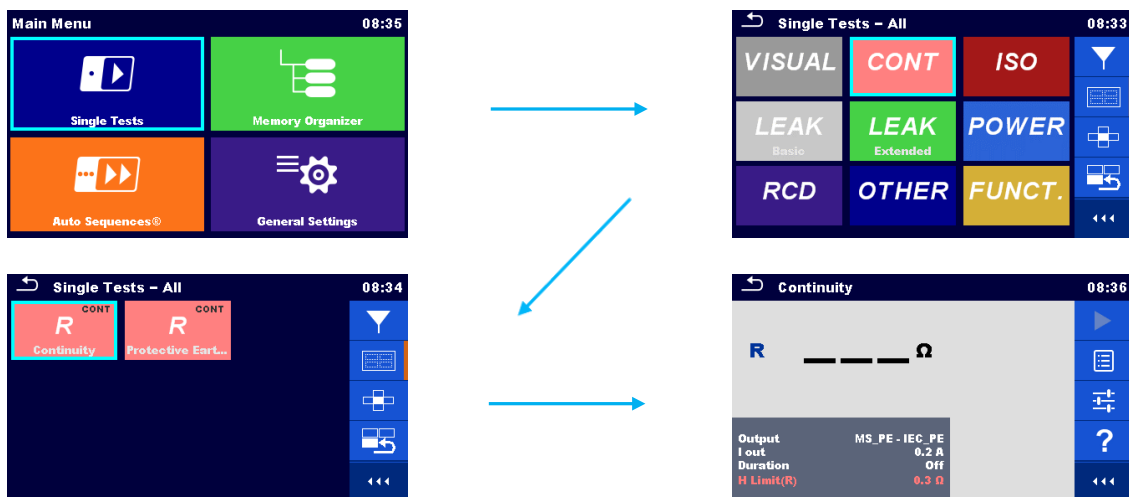

Figure 32_Earth continuity setup

Measuring function: R Continuity / Continuity

Output parameter: MS_PE – IEC_PE

I out: 0.2 A

Limit: $\leq 0.3 \Omega$ (with connecting cables up to 5 m in length) | plus 0.1Ω for each additional 7.5 m up to max. 1.0Ω

Measurement procedure

- Connect EV cable according to connection diagram,
- Set appropriate measurement parameters,
- Start the test.

Compensation of test leads



Figure 33_Test leads compensation

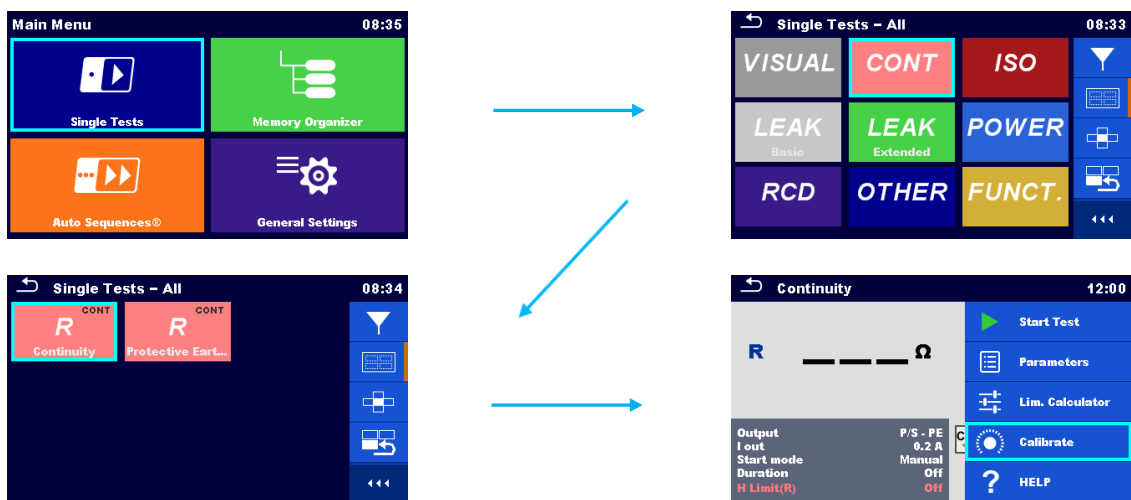

Figure 34_Calibration setup

Compensation procedure

- Connect test leads according to connection diagram,
- Select appropriate measurement,
- Start the calibration.

II. Test setup (EV set to charging status)

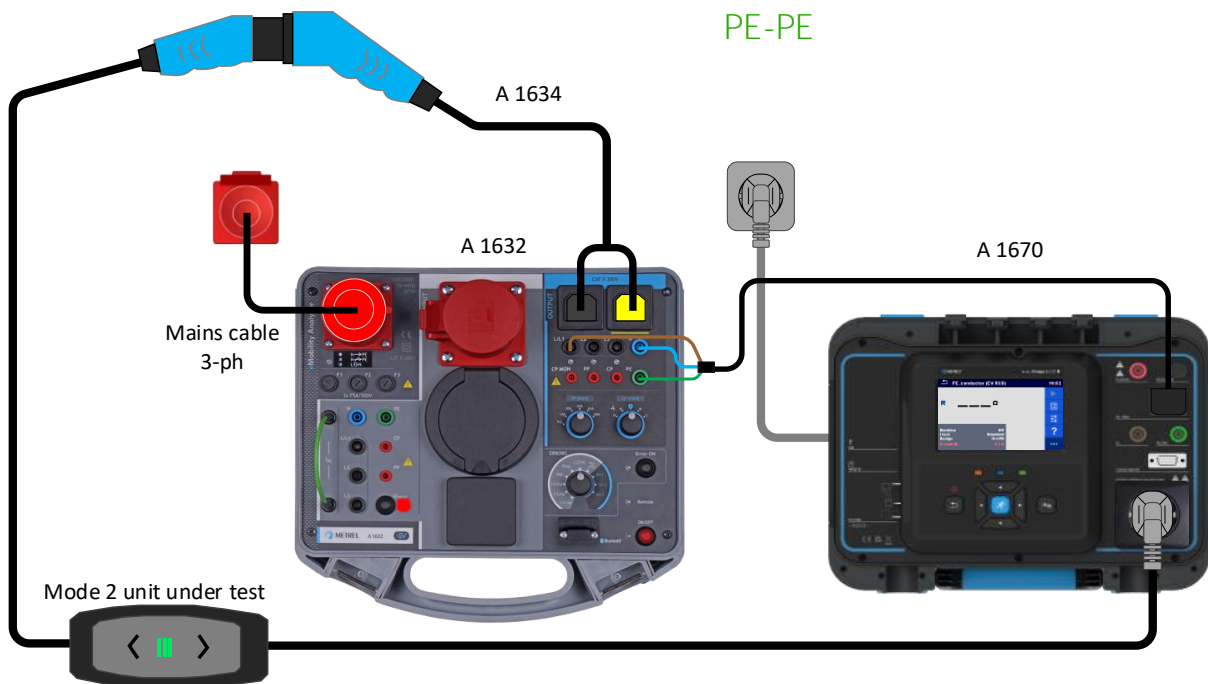

Figure 35_Continuity of protective earth

Test step	Test lead	A 1632	MI 3365
1	A 1670	PE	IEC/PRCD
1	A 1670	N	IEC/PRCD
1	A 1670	L1	IEC/PRCD

Table 16_Test leads setup

Notes!

- Cord must be folded during test! If the result is changing during the measurement this means that the test failed.
- In order to perform measurement accurately the resistance of test leads should be compensated prior to execution of the Continuity test.

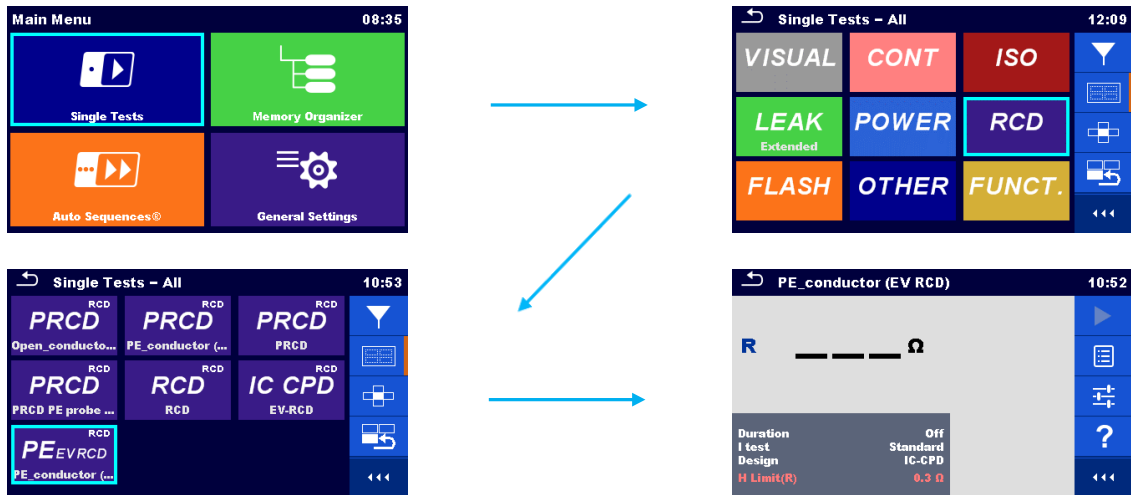

Figure 36_Earth continuity setup

Measuring function: PEEVRCD / PE_conductor (EV RCD)

Design: IC-CPD / (Observe manufacturer information for proper operation.)

I test: Standard

Limit: ≤ 0.3 Ω (with connecting cables up to 5 m in length) | plus 0.1 Ω for each additional 7.5 m up to max. 1.0 Ω

Measurement procedure

Step 1	Step 2	Step 3	Step 4	Step 5	Step 6	Step 7	Step 8	Step 9
Switch CP STATE	Key UINPUT	Status	Status	Switch CP STATE	Status	Switch CP STATE	Status	Switch CP STATE
A 1632	A 1632	MI 3365	MI 3365	A 1632	MI 3365	A 1632	MI 3365	A 1632
Not connected Status A	UINPUT = On	Start test 	Turn on equipment. Set device from state A to state C.	Charging Status C	Set device to state A. Note: for some devices not needed.	Not connected Status A	Turn on equipment. Set device from state A to state C.	Charging Status C
Turn off the UINPUT key, set switch CP state to Status A. Proceed to next step.								

Table 17_EV-RCD test procedure

Notes!

- Some IC CPD's are able to detect the PE leakage current. For such devices set (I test) to Low.
- Some IC CPD's have auto-restart function, for such devices steps 6 & 7 can be skipped.

Compensation of test leads



Figure 37_Test leads compensation

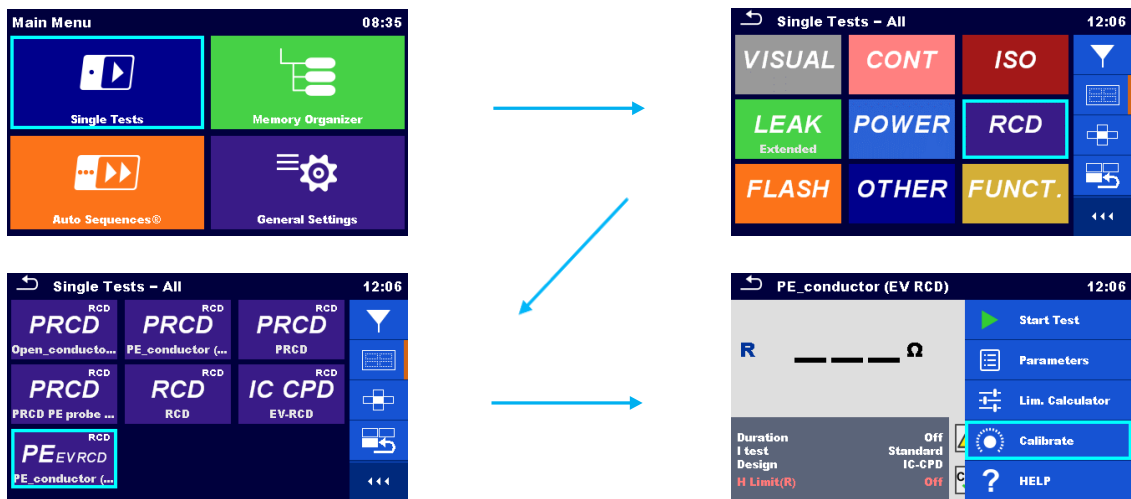

Figure 38_Calibration setup

Compensation procedure

- Connect test leads according to connection diagram,
- Select appropriate measurement,
- Start the calibration.

Insulation resistance of the protective conductor to the neutral and phase conductor

Scope of test:

With the insulation resistance measurement, the confirmation of the effectiveness of the insulation resistance between live parts and accessible conductive parts connected to protective earth is evaluated. This test discloses faults caused by pollution, moisture, deterioration of insulation material etc.

The measurement is performed using the MI 3365 & A 1632. The subject of evaluation is the insulation resistance between the PE conductor, and the live parts on the secondary side of the Mode 2 cable.

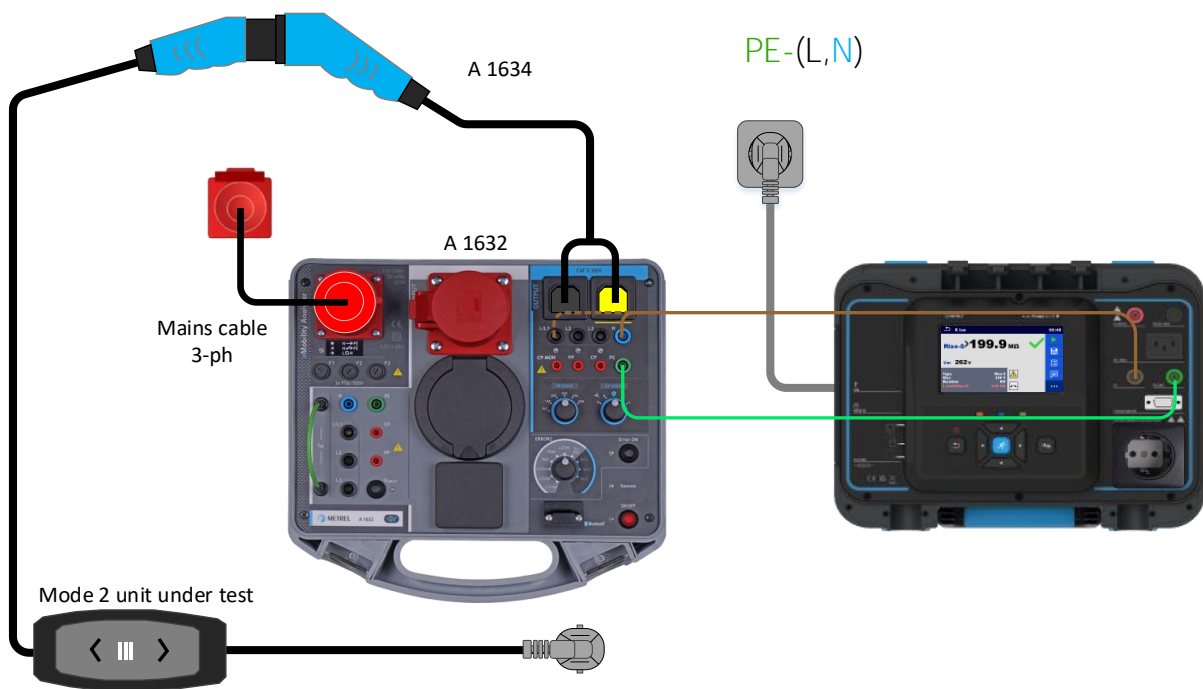

Figure 39_Insulation resistance

Test step	Test lead	A 1632	MI 3365
1 – 2	Green lead	PE	PE
1	Brown lead	N	LN
2	Brown lead	L1	LN

Table 18_Test leads setup

Note!

All live parts shall be subject to test. Reconnect LN/probe on A 1632 output side for evaluation of each live part separately.

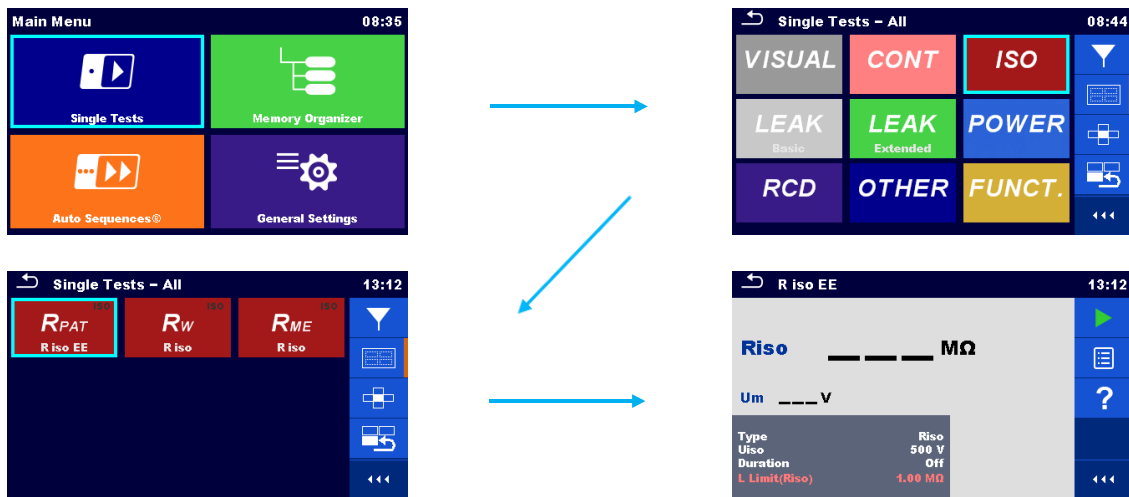

Figure 40_Insulation resistance setup

Measuring function: RPAT / Riso EE

Output parameter: Riso

Uiso: 250 V, 500 V (Observe manufacturers information for appropriate test voltage)

Limit: $\geq 1,0 \text{ M}\Omega$ (secondary side)

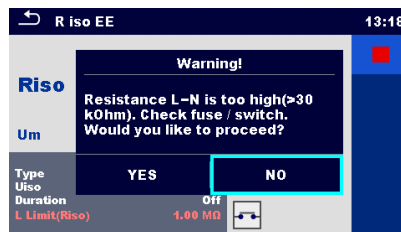

Figure 41_Insulation resistance warning

Insulation resistance pre-test is intended to warn the user for following possible causes:

- Device under test is not connected or switched on
- Input fuse of device under test is blown.

In this application the warning message is irrelevant as the test is made on the secondary side of the cable only.

Select **YES** to proceed with or **NO** to cancel measurement.

Note!

Warning message can be disabled under the settings, in the instruments setup menu! Load pretest (On/Off).

Protective conductor current

Scope of test:

With the PE leakage current measurement, compliance with the limits for the leakage current is evaluated. Using this method, the leakage current that would occur whilst the electrical equipment is in typical use is measured.

Device must be placed isolated against ground to prevent that a part of the leakage current would flow directly to ground instead through the PE conductor and ground.

Unearthed accessible conductive parts are not included in this test. They are considered as class II parts and are checked in the Touch Leakage test.

The measurement is performed using the MI 3365 & A 1632. The subject of evaluation is the insulation resistance and capacitance between the PE conductor, and the live parts of the Mode 2 cable.

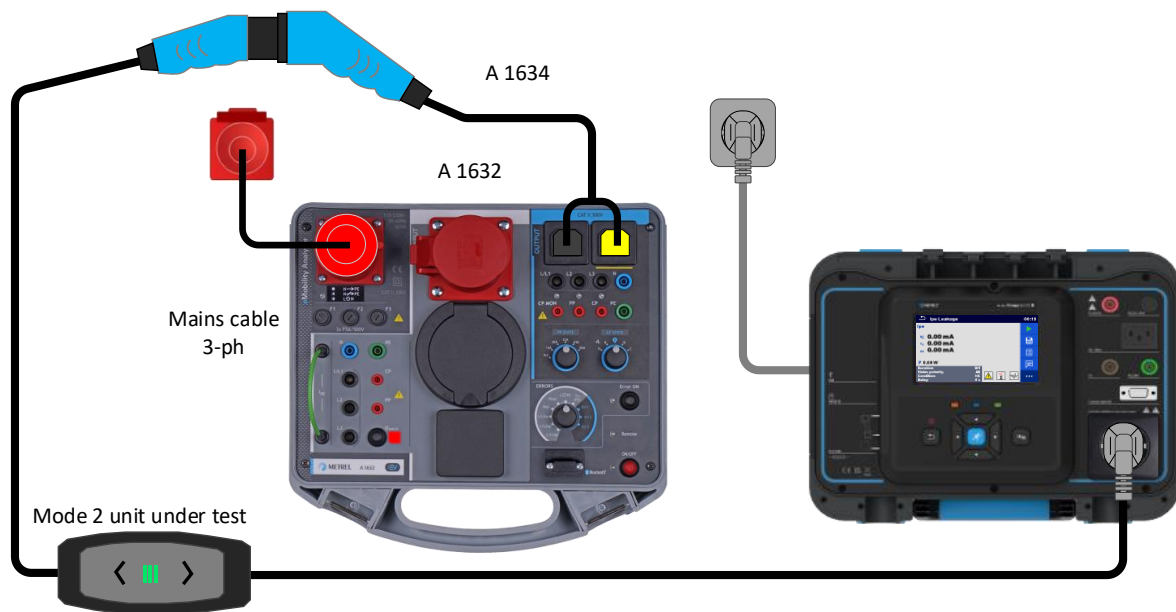

Figure 42_PE leakage current

Note!

Mode 2 cable shall be set to charging mode (Status C) using CP STATE switch of the A 1632, UINPUT key is set to On

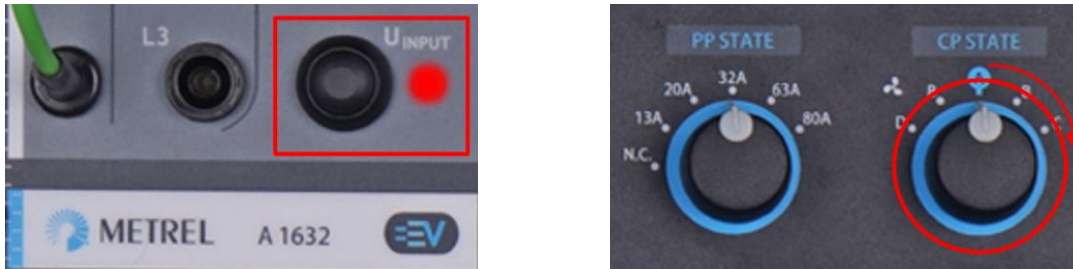

Figure 43_A 1632 keys and switches

*Switching between steps shall be performed dynamically from A → C.
Delay between switching depends on the design of the EVSE.

Step	Key U _{INPUT}	Switch CP STATE
1.	U _{INPUT} = On	Not connected Status A
2.	U _{INPUT} = On	Connected Status B
3.	U _{INPUT} = On	Charging Status C

Table 19_Mode 2 cable setup

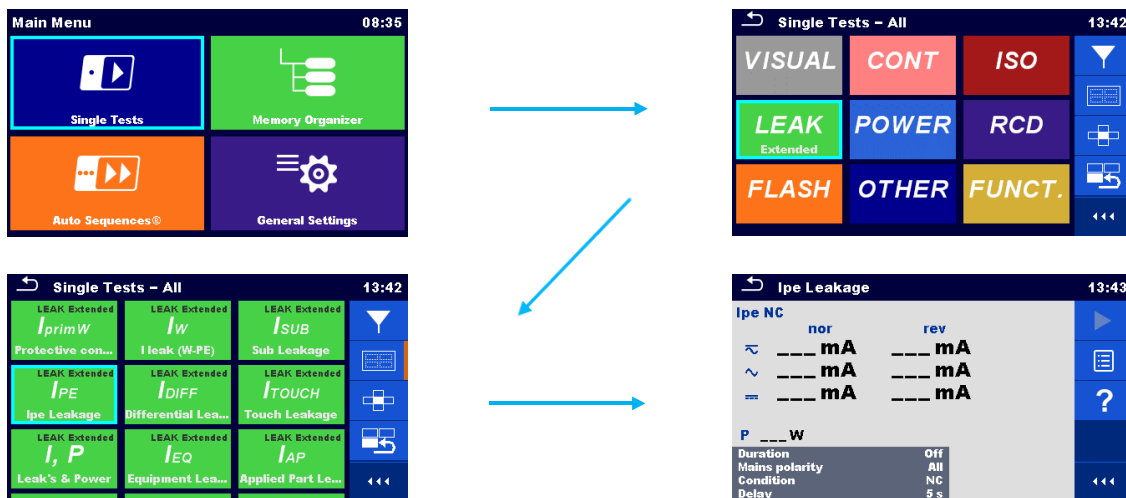

Figure 44_Current clamp setup

Measuring function: Ipe Leakage

Test: PE leakage

Limit: ≤ 3,5 mA

Compliance with tripping current EV-RCD

Scope of test:

With the EV-RCD test the effectiveness of the protective device is evaluated.

The EV-RCD in the Mode 2 cable provides an additional layer of electrical safety by monitoring the current flow and cutting off the power in the event of a fault or leakage. Testing the EV-RCD ensures that it is functioning correctly and can provide the necessary protection against electric shocks.

Remember to refer to the manufacturer's instructions or consult with a qualified electrician to ensure the correct testing procedures for EV-RCDs in Mode 2 EV cables, as they may vary depending on the specific model and regulations in your location.

According to EN 50699 and the German guideline for E-Mobility, the confirmation of the operation of further protective measures needs to be evaluated if the equipment under test includes such parts. This part is in our case EV-RCD.

Generally, it is enough to test only the ability of the EV-RCD to trip in case of fault.

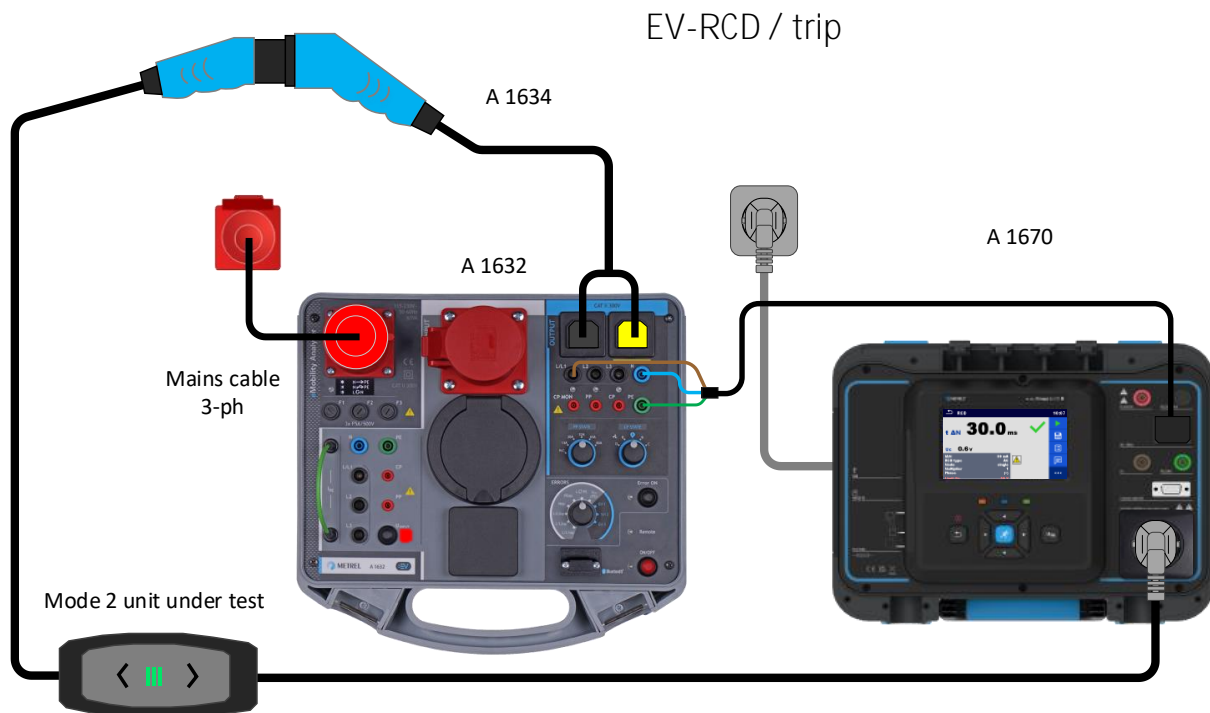

Figure 45_EV-RCD_Test method_internal

Test step	Test lead	A 1632	MI 3365
1	A 1670	PE	IEC/PRCD
1	A 1670	N	IEC/PRCD
1	A 1670	L1	IEC/PRCD

Table 20_Test leads setup

Notes!

- Functionality of the EV-RCD is evaluated on phase L1.
- Mode 2 cable shall be set to charging mode (Status C) using CP STATE switch of the A 1632.

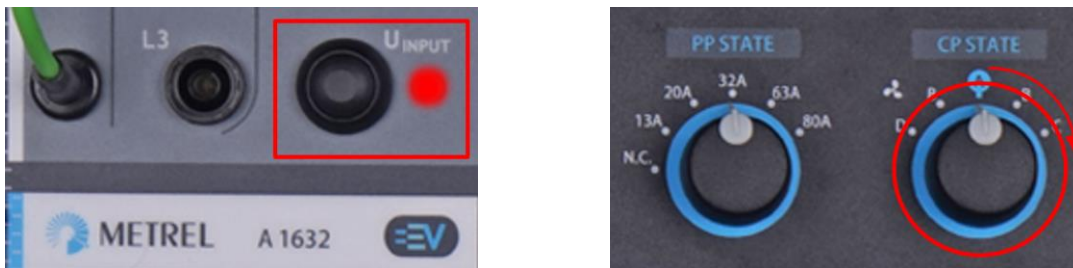

Figure 46_A 1632 keys and switches

The measurement is performed using the MI 3365 & A 1632. The subject of evaluation is EV-RCD of the Mode 2 cable.

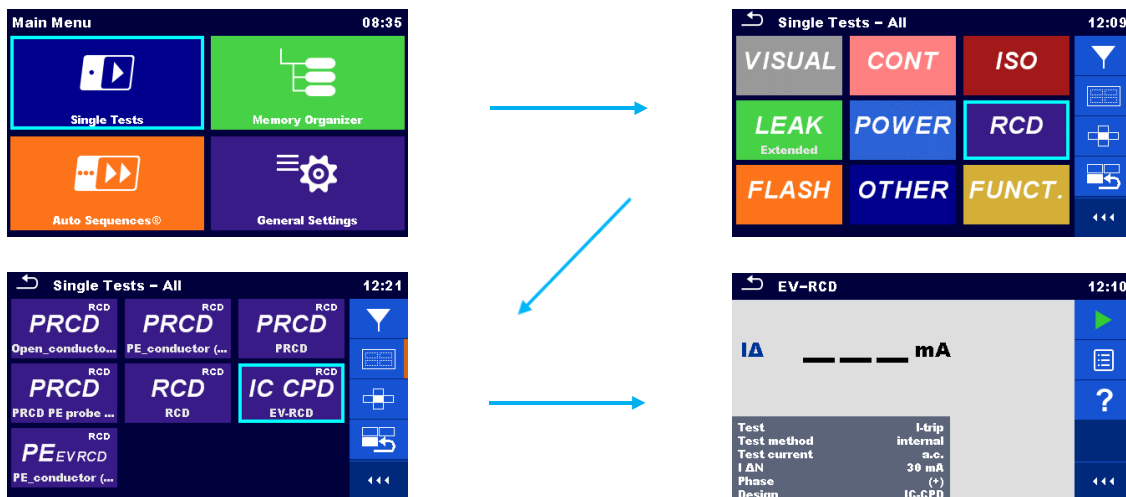

Figure 47_EV-RCD test setup

Measuring function: IC CPD / EV-RCD

Test method: internal / external

Test: t-trip / I-trip

Limit: $I\Delta N_a < I\Delta N$

Measurement procedure >> Internal <<

Step 1	Step 2	Step 3	Step 4	Step 5	Step 6	Step 7	Step 8	Step 9
Switch CP STATE	Key UINPUT	Status	Status	Switch CP STATE	Status	Switch CP STATE	Status	Switch CP STATE
A 1632	A 1632	MI 3365	MI 3365	A 1632	MI 3365	A 1632	MI 3365	A 1632
Not connected Status A	UINPUT = On	Start test 	Turn on equipment. Set device from state A to state C.	Charging Status C	Set device to state A. Note: for some devices not needed.	Not connected Status A	Turn on equipment. Set device from state A to state C.	Charging Status C
Turn off the UINPUT key, set switch CP state to Status A. Proceed to next step.								

Table 21_EV-RCD test procedure

Notes!

- Repeat test procedure for different, EV-RCD settings.
- Some IC CPD's have auto-restart function, for such devices steps 6 & 7 can be skipped.

Proximity Pilot resistor check (Optional)

Scope of test:

Charging speed is determined through the Proximity Pilot (PP). The PP is a resistor connected between the PP pin and the PE pin on the Type 2 connector or socket of a Mode 2 EV cable, a Mode 3 EVSE charging station or the EV. The coding of the resistor actually determines what cable is being used (the cross section) which further determines the maximum charging current and consequently charging speed.

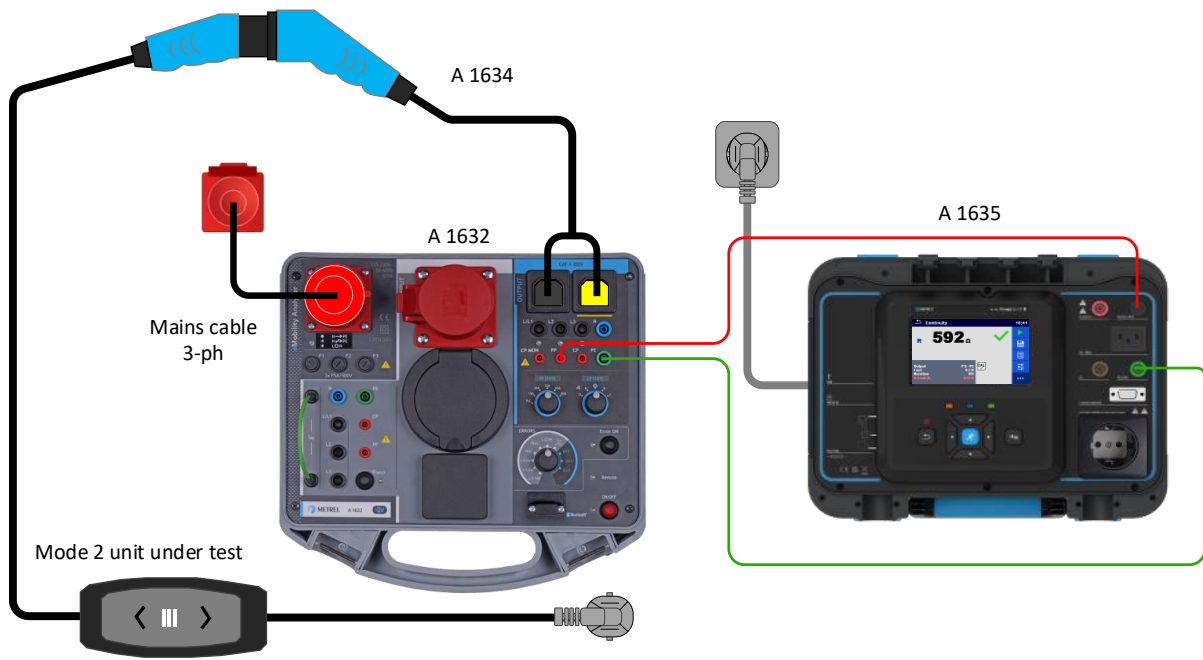

Figure 48_PP resistor_Test

Test lead	A 1632	MI 3365
Red	PP	P/S
Green	PE	PE

Table 22_Test leads setup

Note!

- Rotary switch on the A 1632 shall be set to (Status NC) using PP STATE switch. UINPUT is set to On.

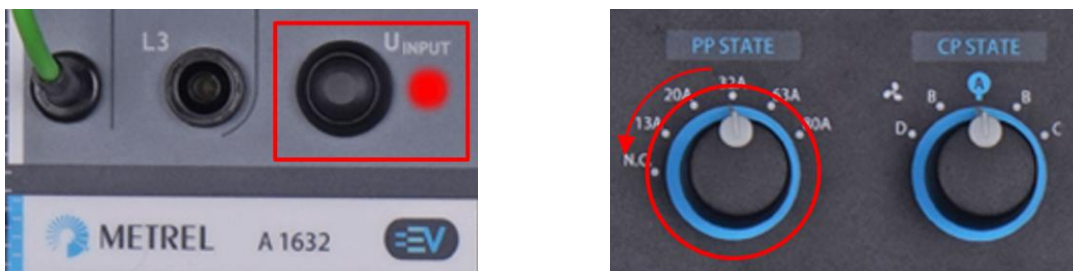
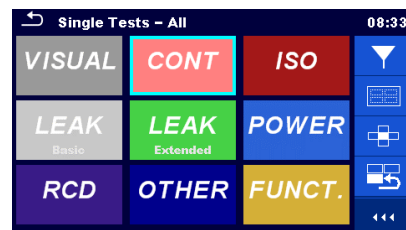
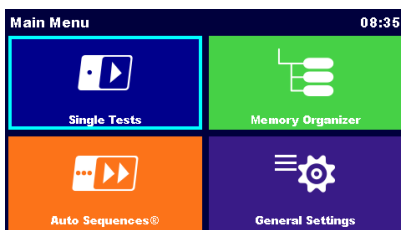

Figure 49_A 1632 keys and switches



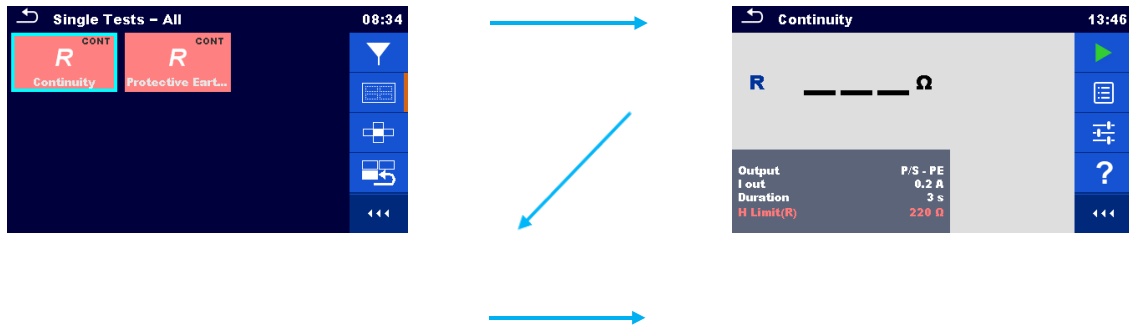

Figure 50_Resistance measurement setup

Measuring function: R Continuity / Continuity

Output parameter: P/S – PE

I_{out}: 0.2 A

Limits: The PP resistor can have the following values according to EN 61851-1:

- 1500 Ω \rightarrow 13 A Charging cable
- 680 Ω \rightarrow 20 A Charging cable
- 220 Ω \rightarrow 32 A Charging cable
- 100 Ω \rightarrow 63 A Charging cable

Error test

Scope of test:

Error test help assess the overall condition and functionality of the Mode 2 EV cable and diagnose the state of the Mode 2 cable protective circuit to react to possible errors present on the input and output side of the cable.

By simulating errors at the Mode 2 cable output, we ensure that in the event of a malfunction on the EV vehicle, the dangerous mains voltage is switched off at the cable output.

Therefore A 1632 has two options for simulating input mains errors:

- Simulation of connection of the charging cable to faulty mains,
- Simulation of a fault that occurs during operation.

By identifying these faults, you can take appropriate measures to repair or replace the cable, ensuring safe and reliable EV charging.



Figure 51_Functional inspection

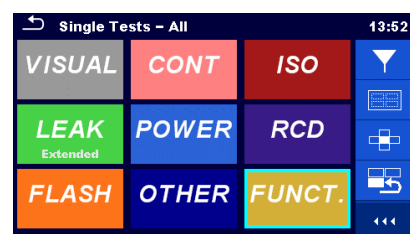
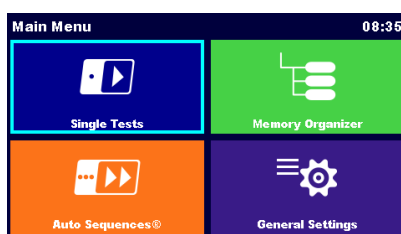

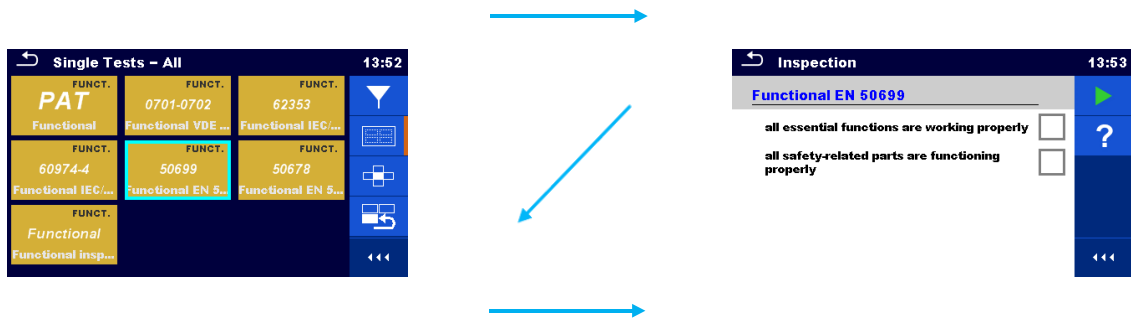

Figure 52_Functional inspection setup

Measurement procedure

Connect the charging cable to the A 1532 (see Figure 28_Mode 2 cable connection).

Set the Errors state rotary switch through all positions clockwise, starting from first position (L/L1op), follow the steps from bellow table.

Check the response of the tested charging cable.

Step	Key U _{INPUT}	Switch ERRORS	Switch CP STATE	Switch Error ON	Test condition
1.	U _{INPUT} = On	INPUT L / L1op	Charging Status C	Error ON/OFF = On	Mains voltage ERROR condition on the input of charging cable, L1 interrupted . Observe output LED's for status.
Turn off the Error ON/OFF key, set switch CP state to Status A. Proceed to next step.					
2.	U _{INPUT} = On	INPUT Nop	Charging Status C	Error ON/OFF = On	Mains voltage ERROR condition on the input of charging cable, N interrupted . Observe output LED's for status.
Turn off the Error ON/OFF key, set switch CP state to Status A. Proceed to next step.					
3.	U _{INPUT} = On	INPUT PEop	Charging Status C	Error ON/OFF = On	Mains voltage ERROR condition on the input of charging cable, PE interrupted . Observe manufacturer information for proper operation.
Turn off the Error ON/OFF key, set switch CP state to Status A. Proceed to next step.					
4.	U _{INPUT} = Off	INPUT L ↻ PE	Charging Status C	Error ON/OFF = On	Mains voltage ERROR condition on the input of charging cable, L_PE switched . The device shall not enter operation mode when set to status C. Observe manufacturer information for proper operation
Turn off the Error ON/OFF key, set switch CP state to Status A. Proceed to next step.					

5.	U _{INPUT} = Off	INPUT U _{EXT} (PE)	Charging Status C	Error ON/OFF = On	Mains voltage ERROR condition on the input of charging cable, External voltage on PE. The device shall not enter operation mode when set to status C. Observe manufacturer information for proper operation
Turn off the Error ON/OFF key, set switch CP state to Status A. Proceed to next step.					
6.	U _{INPUT} = On	OUTPUT PEop	Charging Status C	Error ON/OFF = On	PE opened, EVSE output should de-energize within 100 ms. Observe manufacturer information for proper operation.
Turn off the Error ON/OFF key, set switch CP state to Status A. Proceed to next step.					
7.	U _{INPUT} = On	OUTPUT CPsh	Charging Status C	Error ON/OFF = On	CP - PE shorted, EVSE output should de-energize within 3 s. Observe manufacturer information for proper operation
Turn off the Error ON/OFF key, set switch CP state to Status A. Proceed to next step.					
*8.	U _{INPUT} = On	OUTPUT →sh	Charging Status C	Error ON/OFF = On	CP diode shorted, EVSE output should de-energize within 3 s. Observe manufacturer information for proper operation
Turn off the Error ON/OFF key, set switch CP state to Status A. Error test finished.					

Table 23_Applicable error test

*CP diode shorted test can be performed optionally.

2. Mode 2 EV cables testing using A 1532

The A 1532 XA is an extender for interfacing Electric Vehicle Supply Equipment (EVSE) to test socket. It is intended for testing Mode 3 EV supply equipment with type 2 connector.

Mode 2 EV Cable testing (1-phase)

List of Applicable test & Limits

Measurements		
Measurement	Measuring method	Limits
Visual Inspection		
Functional inspection		
Continuity of protective conductor	Low resistance measurement	$\leq 0.3 \Omega$ (with connecting cables up to 5 m in length) plus 0.1Ω per additional 7.5 m up to max. 1.0Ω
Insulation resistance of the protective conductor to the neutral and phase conductor	Insulation resistance measurement	$\geq 1.0 \text{ M}\Omega$ (secondary side)
Protective conductor current	Direct method	$\leq 3,5 \text{ mA}$
Compliance with tripping current PRCD	Trip test PRCD	$I\Delta N_a < I\Delta N$
Proximity Pilot resistor check (Optional)		

Table 24_Applicable measurements

Switch CP STATE	Vehicle status	Result
Status A	Vehicle not connected (idle state)	Yes / No
Status B	Vehicle connected but not ready to charge.	Yes / No
Status C	Vehicle connected and ready for charging, charging area ventilation not required	Yes / No

Table 25_Applicable functional statuses

ERRORS	Applied to:	Test condition
PEop	OUTPUT	PE opened / EVSE output should de-energize within 100 ms.
CPsh		CP - PE shorted / EVSE output should de-energize within 3 s.
 sh		CP diode shorted / EVSE output should de-energize within 3 s.

Table 26_Applicable errors

Visual inspection

Scope of test:

The visual inspection shall take place to detect external defects and, if possible, to determine the qualification of the suitability of the equipment for the environment.



Figure 53_Visual inspection

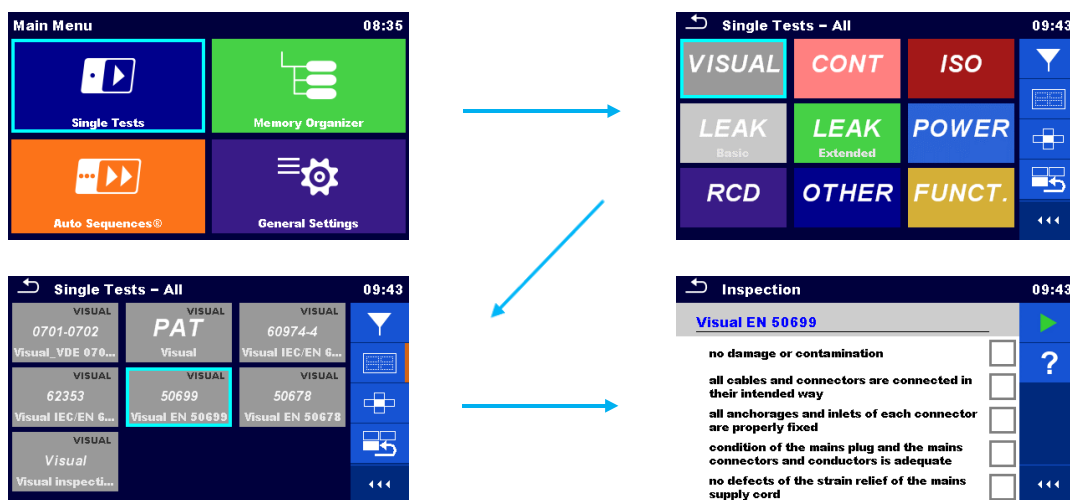

Figure 54_Visual inspection setup

Special attention shall be paid to the following:

- Check there is no damage or contamination,
- check that connectors are connected in their intended way,
- checking by hand to ensure that the anchorages and the inlets of each connector are properly fixed,
- check for defects in the mains lead cord grip,
- check for damage to the housing and protective cover that could give access to live or dangerous parts,
- check for signs of overload or overheating,
- check for signs of corrosion that impact protective measures and improper ageing,
- check for the usability of switches, control and setup equipment,
- check for the defect due to the bending of the cord.

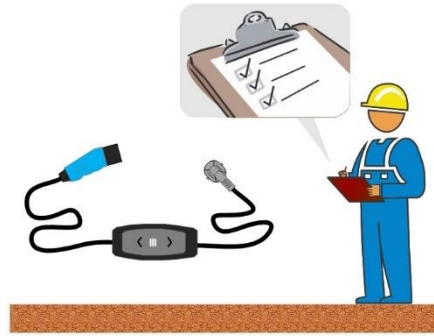

Figure 55_Visual inspection

Functional test

Scope of test:

Functional test of a Mode 2 EV cable is important to ensure that the cable operates properly and safely when charging an electric vehicle and help assess the overall condition and functionality of the Mode 2 EV cable.

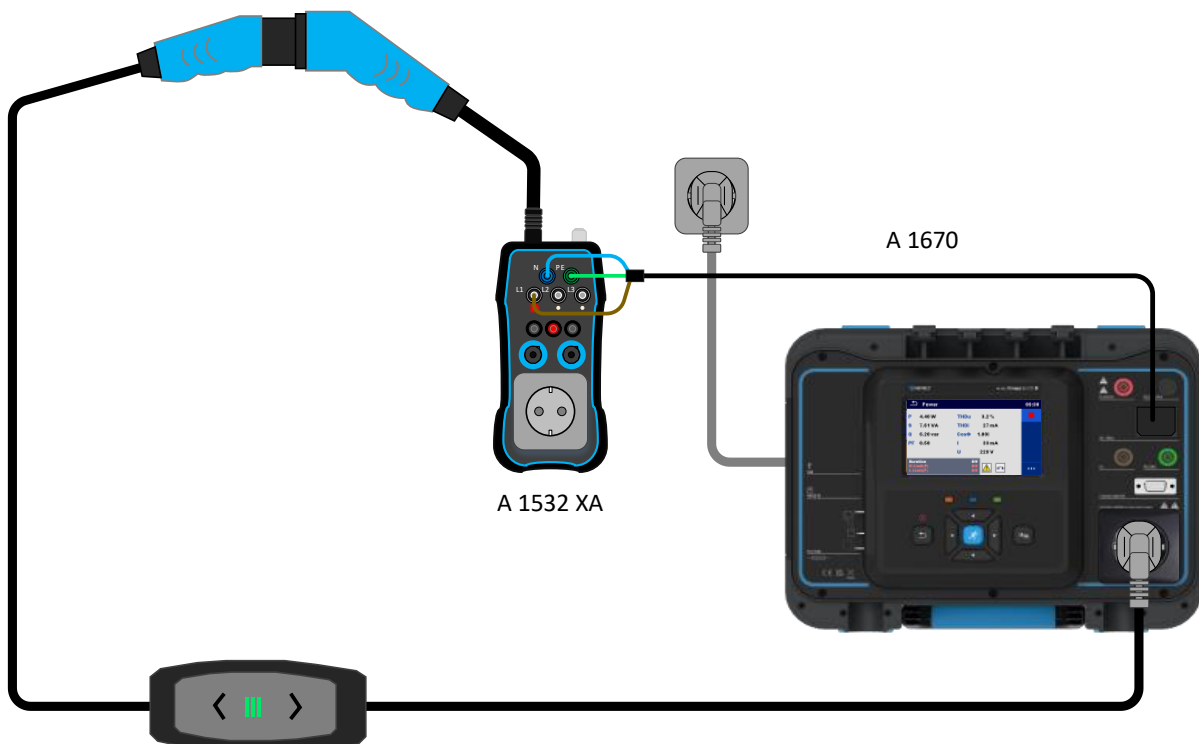

Figure 56_Mode 2 cable connection

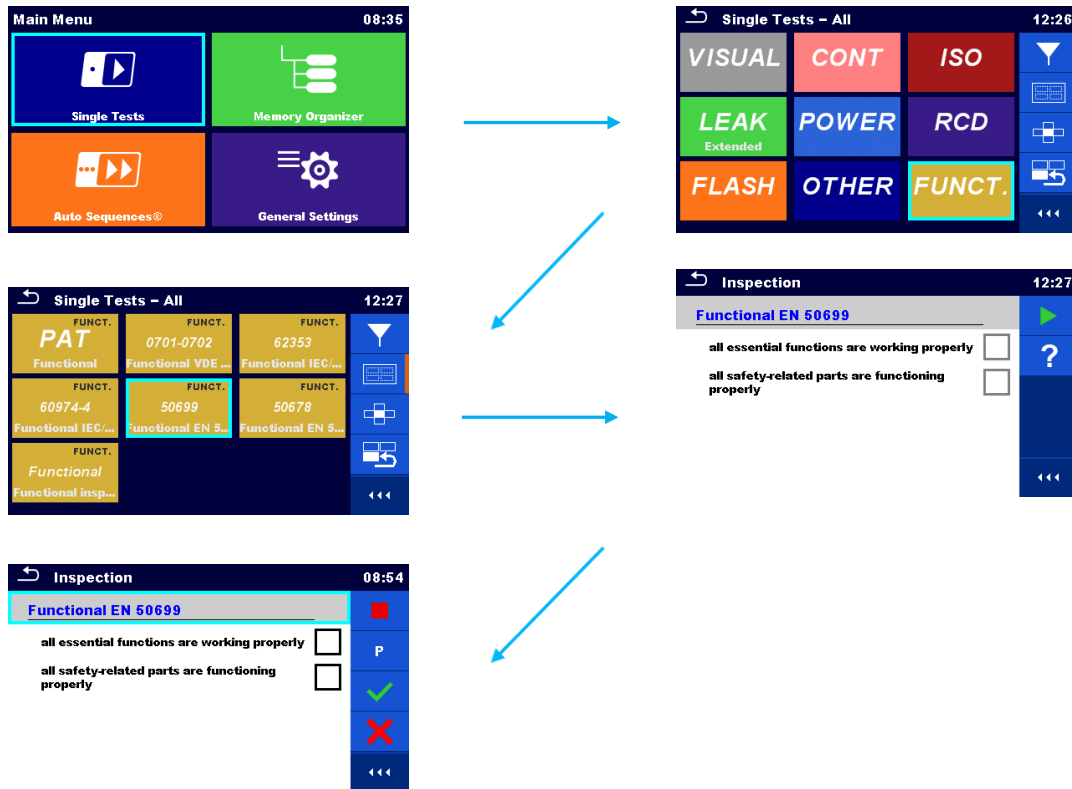

Figure 57_Functional inspection setup

Measurement procedure (EV stations with ventilations are mostly obsolete):

- Connect the charging cable to the EVSE adapter (A 1532 XA) (see Figure 59_Continuity of protective earth).
- Follow the test procedure from bellow table, Table 4_Vehicle status.
- Check the response of the tested charging cable.



Figure 58_A 1532 keys and switches

*Switching between steps shall be performed dynamically from A → C.
 Delay between switching depends on the design of the EVSE.

Step	MI 3365	Switch CP STATE *	Vehicle status	Mode 2 cable condition	Result
1.	Power test = On	Not connected Status A	Vehicle not connected (idle state)	Observe manufacturer information for proper operation.	Yes / No

2.	Power test = On	Connected Status B	Vehicle connected but not ready to charge.	Observe manufacturer information for proper operation.	Yes / No
3.	Power test = On	Charging Status C	Vehicle connected and ready for charging, charging area ventilation not required	Observe manufacturer information for proper operation.	Yes / No
Turn off the Power test, set switch CP state to Status A. Proceed to next step.					

Table 27_Vehicle status

Once confirmed that the Mode 2 cable can be set to status C and it is properly operating, proceed with electrical safety testing.

Continuity of protective conductor

Scope of test:

With the low resistance measurement, the confirmation of the effectiveness of the protective bonding to all accessible conductive parts connected for safety reasons to protective earth is evaluated.

The measurement is performed using the MI 3365 & A 1532. The subject of evaluation is the PE conductor, between the input and the output terminal and/or all accessible earthed parts if applicable.

Some Mode 2 cables should be set to the charging position to evaluate the PE conductor in the cable. Observe manufacturer information for proper operation. Therefore, there are two different test setups applicable:

I. Test setup (EV not set to charging status)

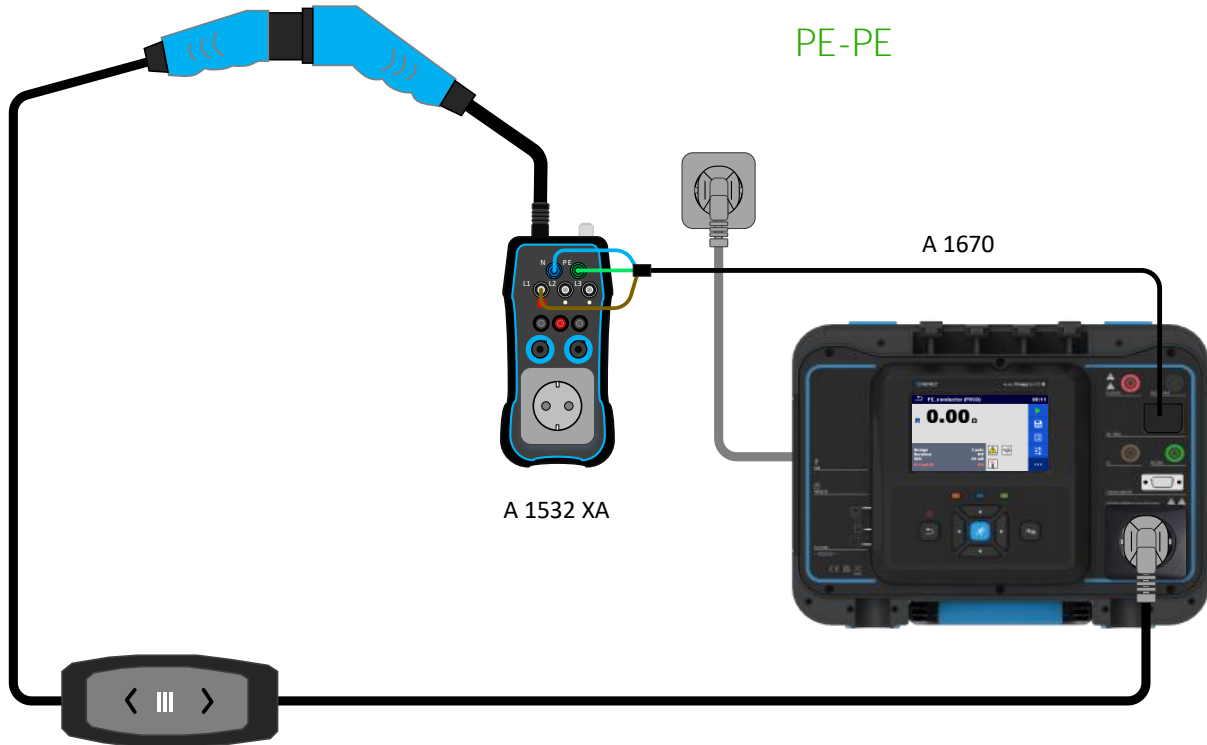

Figure 59_Continuity of protective earth

Test step	Test lead	A 1532	MI 3365
1	A 1670	PE	IEC/PRCD
1	A 1670	N	IEC/PRCD
1	A 1670	L1	IEC/PRCD

Table 28_Test leads setup

Note!

- Cord must be folded during test! If the result is changing during the measurement this means that the test failed.
- In order to perform measurement accurately the resistance of test leads should be compensated prior to execution of the Continuity test.

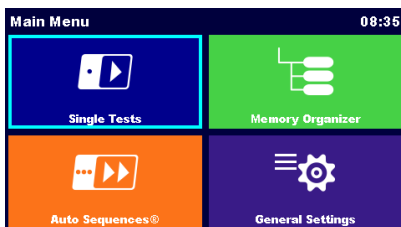

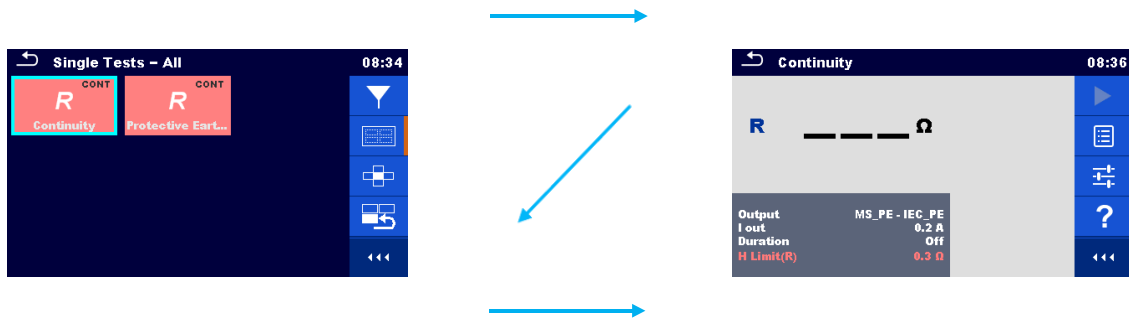

Figure 60_Earth continuity setup

Measuring function: R Continuity / Continuity

Output parameter: MS_PE – IEC_PE

I out: 0.2 A

Limit: $\leq 0.3 \Omega$ (with connecting cables up to 5 m in length) | plus 0.1Ω for each additional 7.5 m up to max. 1.0Ω

Measurement procedure

- Connect EV cable according to connection diagram,
- Set appropriate measurement parameters,
- Start the test.

Compensation of test leads



Figure 61_Test leads compensation

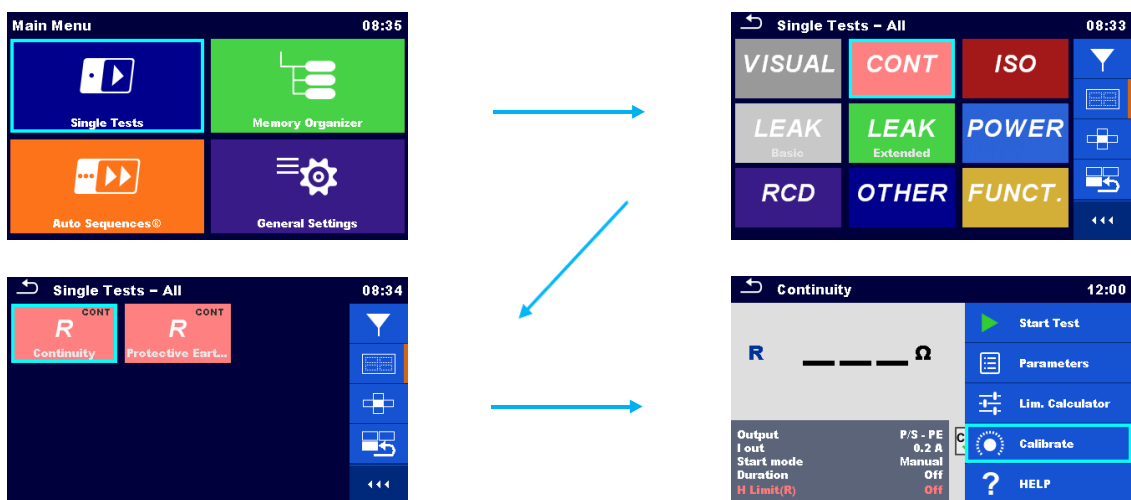

Figure 62_Calibration setup

Compensation procedure

- Connect test leads according to connection diagram,
- Select appropriate measurement,

- Start the calibration.

II. Test setup (EV set to charging status)

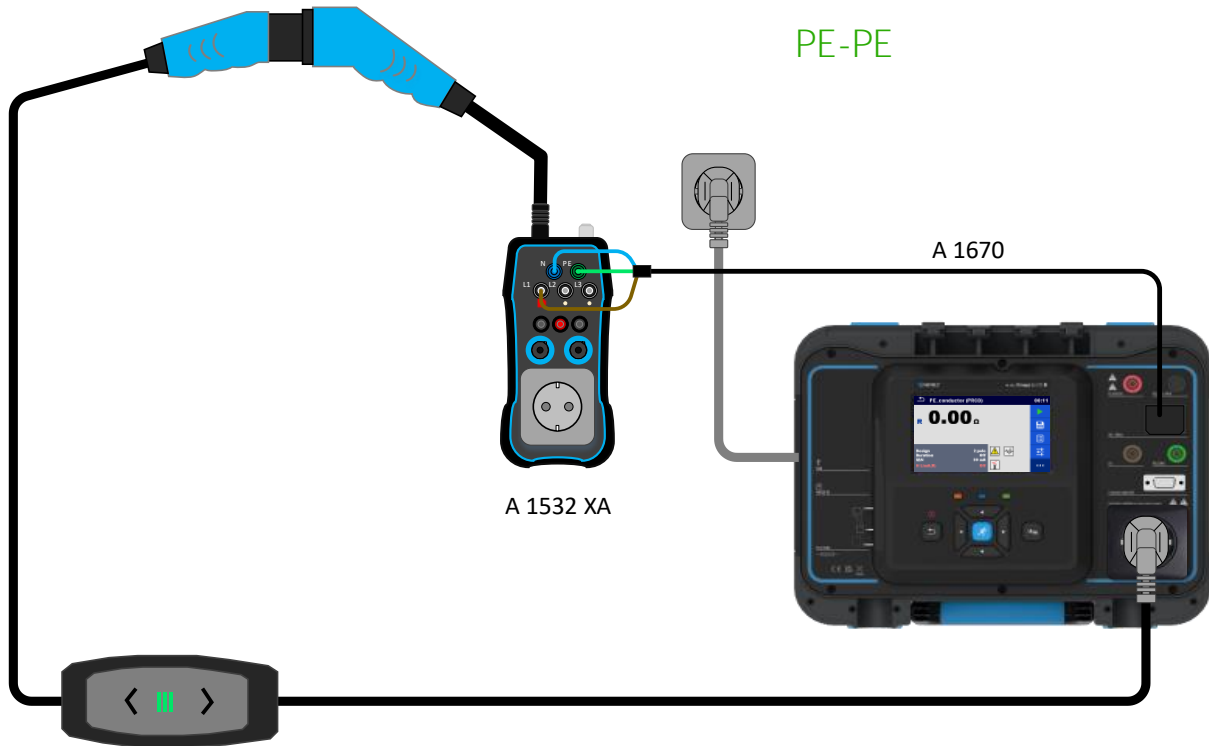

Figure 63_Continuity of protective earth

Test step	Test lead	A 1532	MI 3365
1	A 1670	PE	IEC/PRCD
1	A 1670	N	IEC/PRCD
1	A 1670	L1	IEC/PRCD

Table 29_Test leads setup

Note!

Cord must be folded during test! If the result is changing during the measurement this means that the test failed.

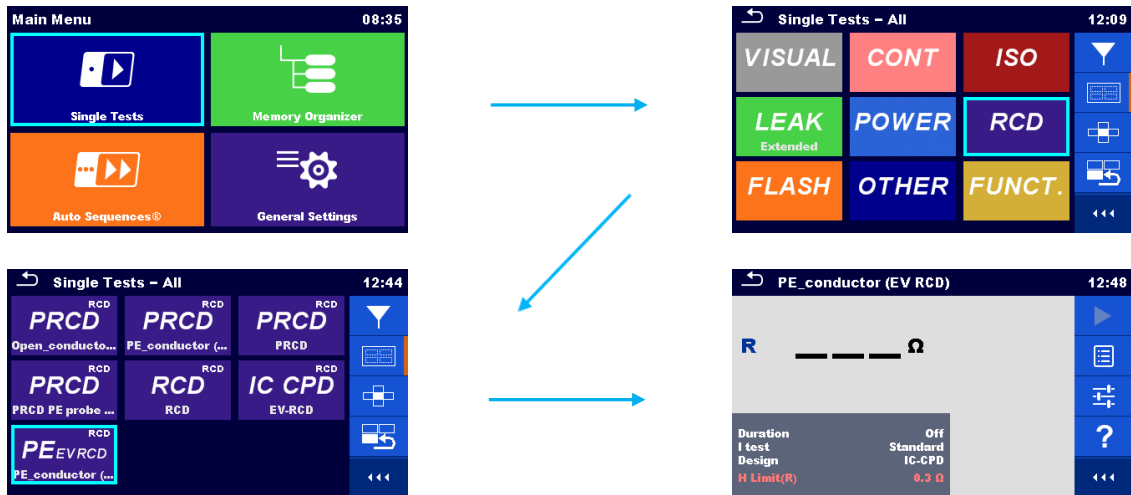

Figure 64_Earth continuity setup

Measuring function: PEEVRCD / PE_conductor (EV RCD)

Design: IC-CPD / (Observe manufacturer information for proper operation.)

I test: Standard

Limit: ≤ 0.3 Ω (with connecting cables up to 5 m in length) | plus 0.1 Ω for each additional 7.5 m up to max. 1.0 Ω

Measurement procedure

		15s		6s		15s	
Step 1	Step 2	Step 3	Step 4	Step 5	Step 6	Step 7	Step 8
Switch CP STATE	Status	Status	Switch CP STATE	Status	Switch CP STATE	Status	Switch CP STATE
A 1532	MI 3365	MI 3365	A 1532	MI 3365	A 1532	MI 3365	A 1532
Not connected Status A	Start test 	Turn on equipment. Set device from state A to state C.	Charging Status C	Set device to state A. Note: for some devices not needed.	Not connected Status A	Turn on equipment. Set device from state A to state C.	Charging Status C
Stop the PE conductor test, set switch CP state to Status A. Proceed to next step.							

Table 30_EV-RCD test procedure

Notes!

- Some IC CPD's are able to detect the PE leakage current. For such devices set (I test) to Low.
- Some IC CPD's have auto-restart function, for such devices steps 6 & 7 can be skipped.
- In order to perform measurement accurately the resistance of test leads should be compensated prior to execution of the Continuity test.

Compensation of test leads



Figure 65_Test leads compensation

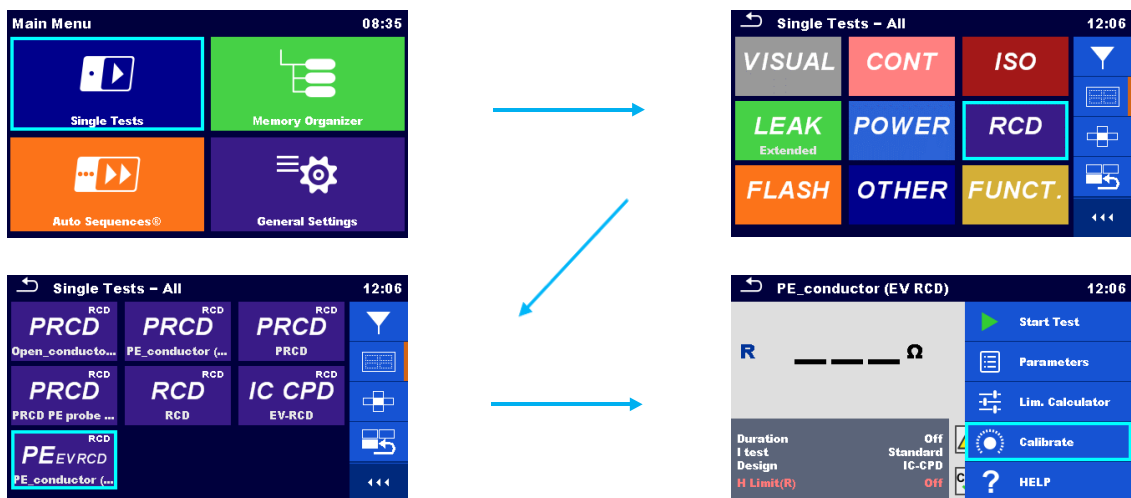

Figure 66_Calibration setup

Compensation procedure

- Connect test leads according to connection diagram,
- Select appropriate measurement,
- Start the calibration.

Insulation resistance of the protective conductor to the neutral and phase conductor

Scope of test:

With the insulation resistance measurement, the confirmation of the effectiveness of the insulation resistance between live parts and accessible conductive parts connected to protective earth is evaluated. This test discloses faults caused by pollution, moisture, deterioration of insulation material etc.

The measurement is performed using the MI 3365 & A 1532. The subject of evaluation is the insulation resistance between the PE conductor, and the live parts on the secondary side of the Mode 2 cable.

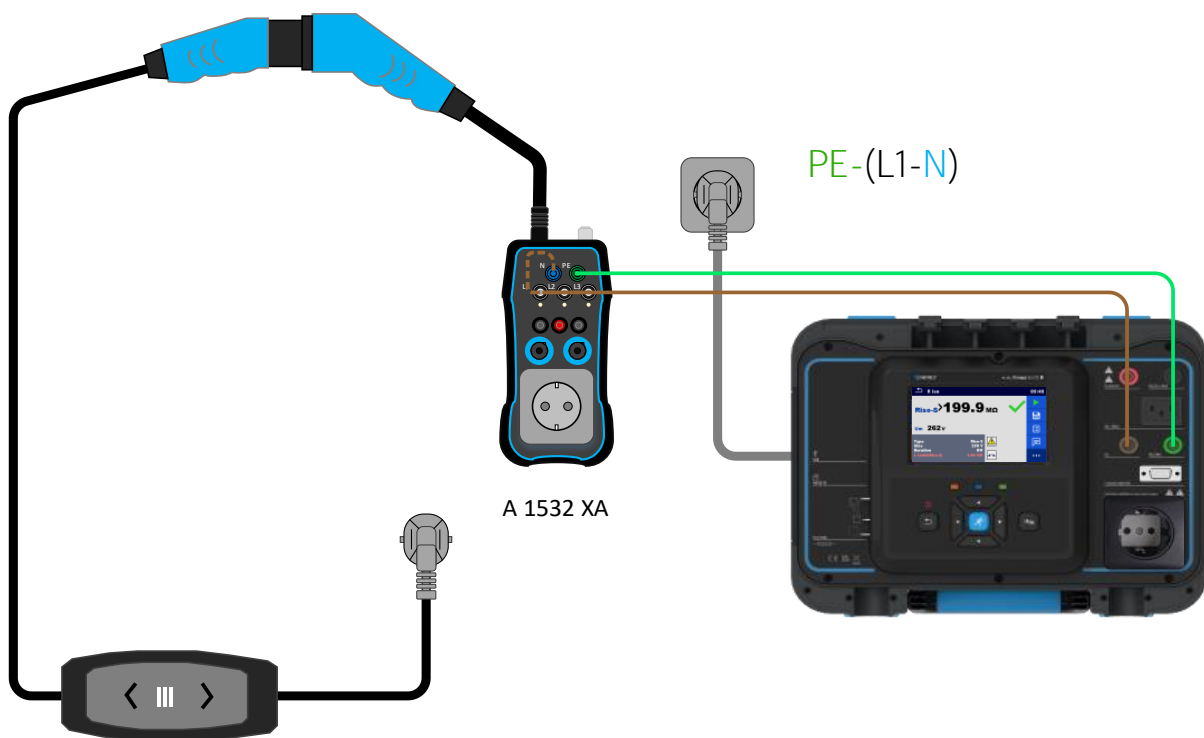

Figure 67_Insulation resistance

Test step	Test lead	A 1532	MI 3365
1 – 2	Green lead	PE	PE
1	Brown lead	N	LN
2	Brown lead	L1	LN

Table 31_Test leads setup

Note!

All live parts shall be subject to test. Reconnect LN/probe on A 1532 output side for evaluation of each live part separately.

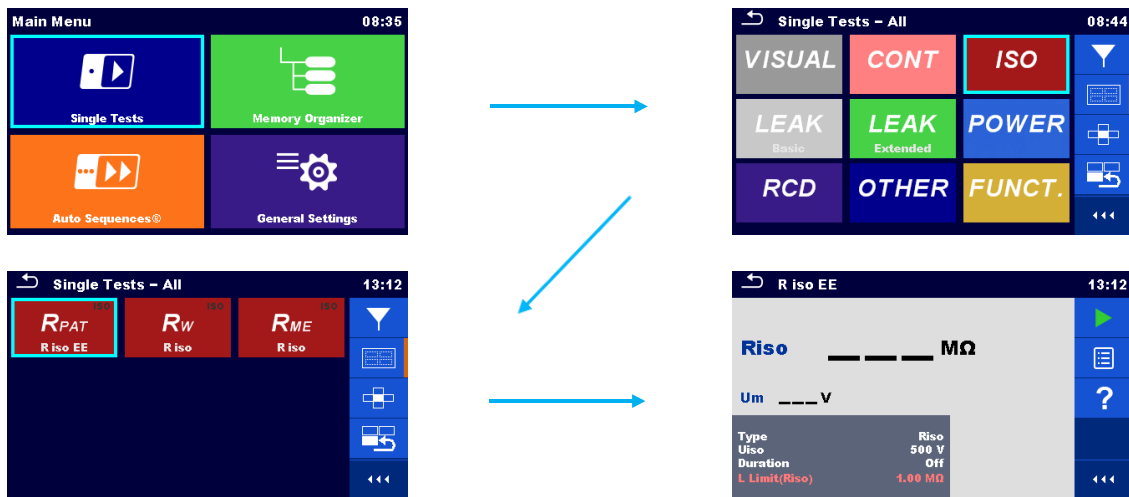

Figure 68_Insulation resistance setup

Measuring function: R_{PAT} / Riso EE

Output parameter: Riso

Uiso: 250 V, 500 V (Observe manufacturers information for appropriate test voltage)

Limit: $\geq 1,0 \text{ M}\Omega$ (secondary side)

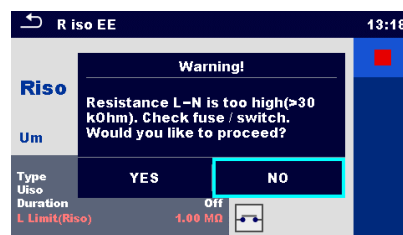

Figure 69_Insulation resistance warning

Insulation resistance pre-test is intended to warn the user for following possible causes:

- Device under test is not connected or switched on
- Input fuse of device under test is blown.

In this application the warning message is irrelevant as the test is made on the secondary side of the cable only.

Select **YES** to proceed with or **NO** to cancel measurement.

Note!

Warning message can be disabled under the settings, in the instruments setup menu! Load pretest (On/Off).

Protective conductor current

Scope of test:

With the PE leakage current measurement, compliance with the limits for the leakage current is evaluated. Using this method, the leakage current that would occur whilst the electrical equipment is in typical use is measured.

Device must be placed isolated against ground to prevent that a part of the leakage current would flow directly to ground instead through the PE conductor and ground.

Unearthed accessible conductive parts are not included in this test. They are considered as class II parts and are checked in the Touch Leakage test.

The measurement is performed using the MI 3365 & A 1532. The subject of evaluation is the insulation resistance and capacitance between the PE conductor, and the live parts of the Mode 2 cable.

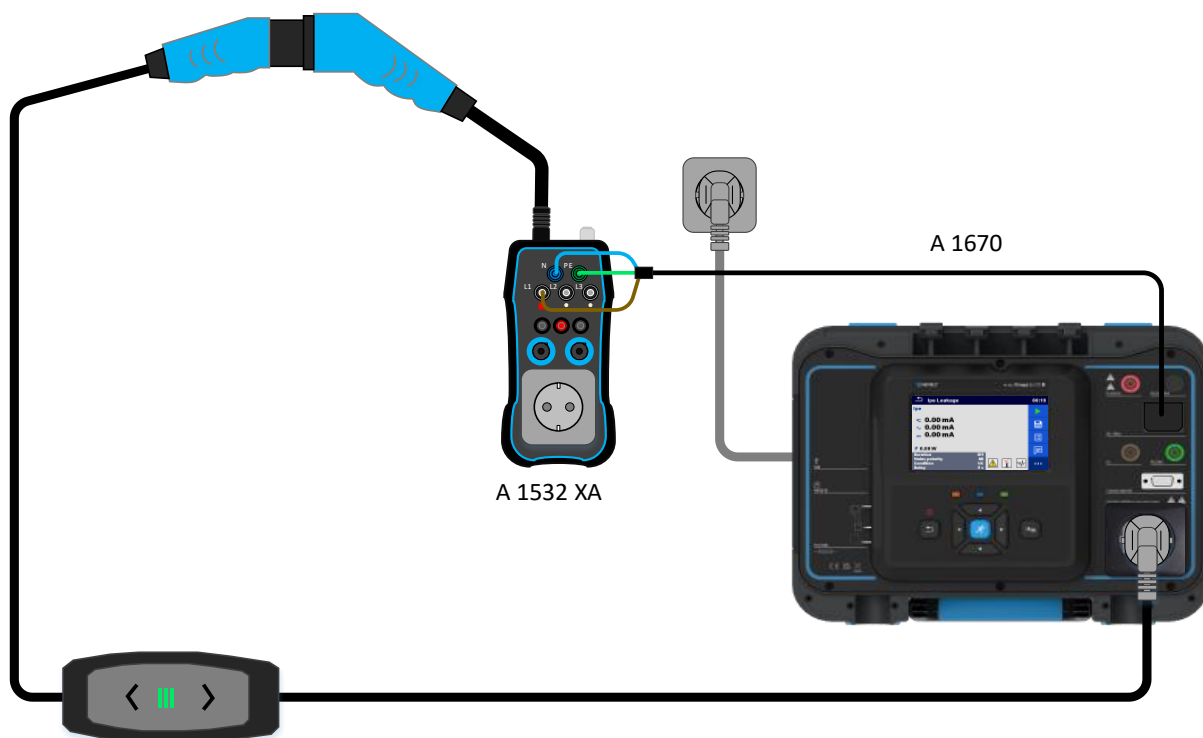

Figure 70_PE leakage current

Note!

Mode 2 cable shall be set to charging mode (Status C) using CP STATE switch of the A 1532, UINPUT key is set to On



Figure 71_A 1532 keys and switches

*Switching between steps shall be performed dynamically from A → C.
Delay between switching depends on the design of the EVSE.

Step	Key UINPUT	Switch CP STATE
1.	PE Leakage test = On	Not connected Status A
2.	PE Leakage test = On	Connected Status B
3.	PE Leakage test = On	Charging Status C

Table 32_Mode 2 cable setup

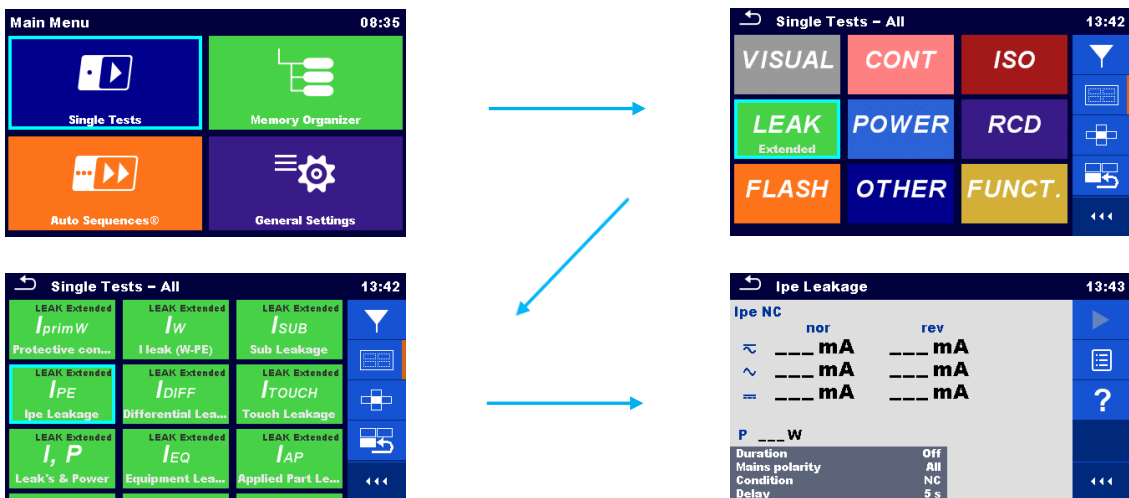

Figure 72_Current clamp setup

Measuring function: Ipe Leakage

Test: PE leakage

Limit: ≤ 3,5 mA

Compliance with tripping current EV-RCD

Scope of test:

With the EV-RCD test the effectiveness of the protective device is evaluated.

The EV-RCD in the Mode 2 cable provides an additional layer of electrical safety by monitoring the current flow and cutting off the power in the event of a fault or leakage. Testing the EV-RCD ensures that it is functioning correctly and can provide the necessary protection against electric shocks.

Remember to refer to the manufacturer's instructions or consult with a qualified electrician to ensure the correct testing procedures for EV-RCDs in Mode 2 EV cables, as they may vary depending on the specific model and regulations in your location.

According to EN 50699 and the German guideline for E-Mobility, the confirmation of the operation of further protective measures needs to be evaluated if the equipment under test includes such parts. This part is in our case EV-RCD.

Generally, it is enough to test only the ability of the EV-RCD to trip in case of fault.

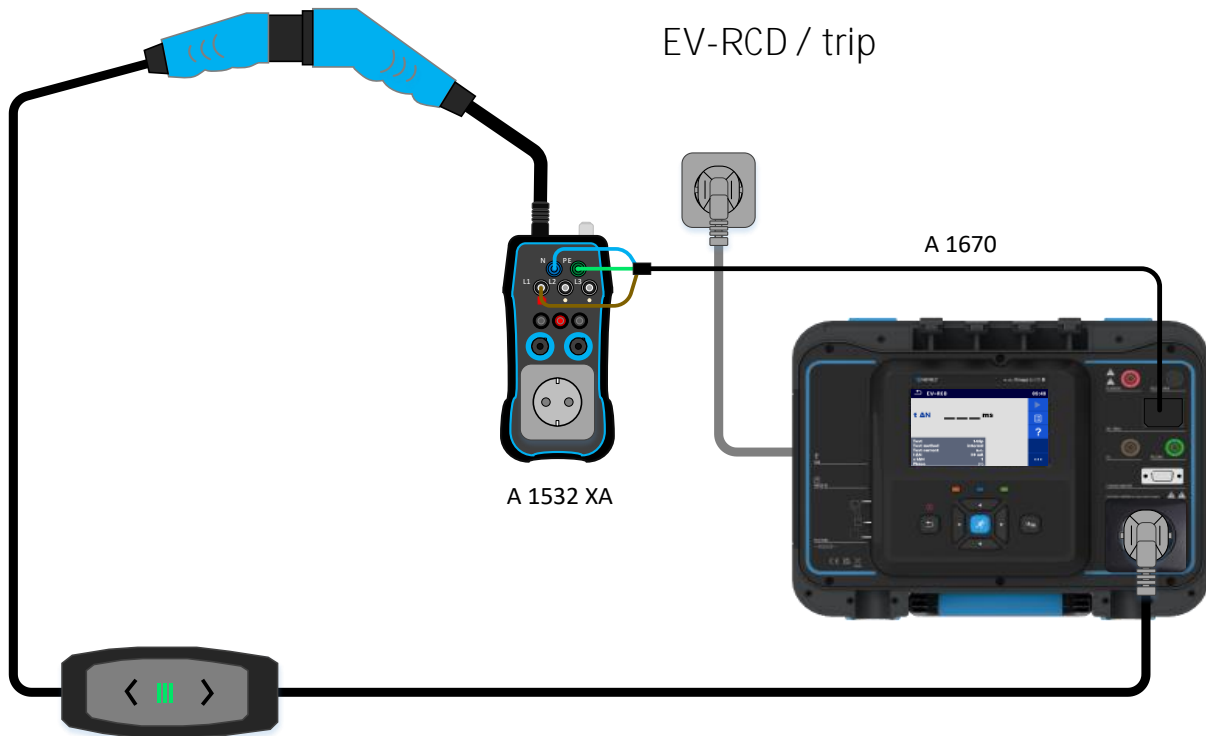

Figure 73_EV-RCD_Test method_internal

Test step	Test lead	A 1532	MI 3365
1	A 1670	PE	IEC/PRCD
1	A 1670	N	IEC/PRCD
1	A 1670	L1	IEC/PRCD

Table 33_Test leads setup

Notes!

- Functionality of the EV-RCD is evaluated on phase L1.
- Mode 2 cable shall be set to charging mode (Status C) using CP STATE switch of the A 1532.

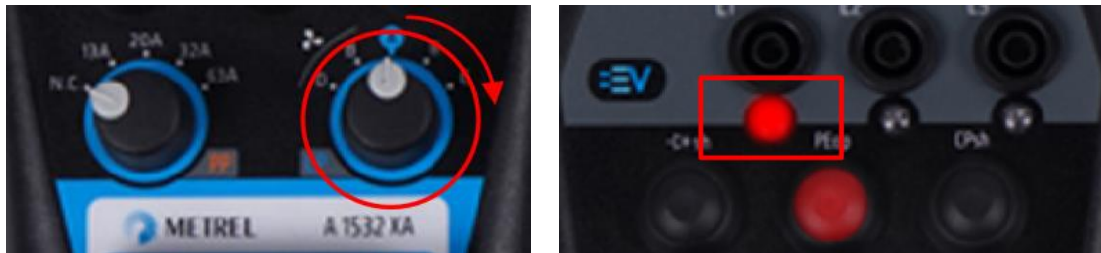

Figure 74_A 1532 keys and switches

The measurement is performed using the MI 3365 & A 1532. The subject of evaluation is EV-RCD of the Mode 2 cable.

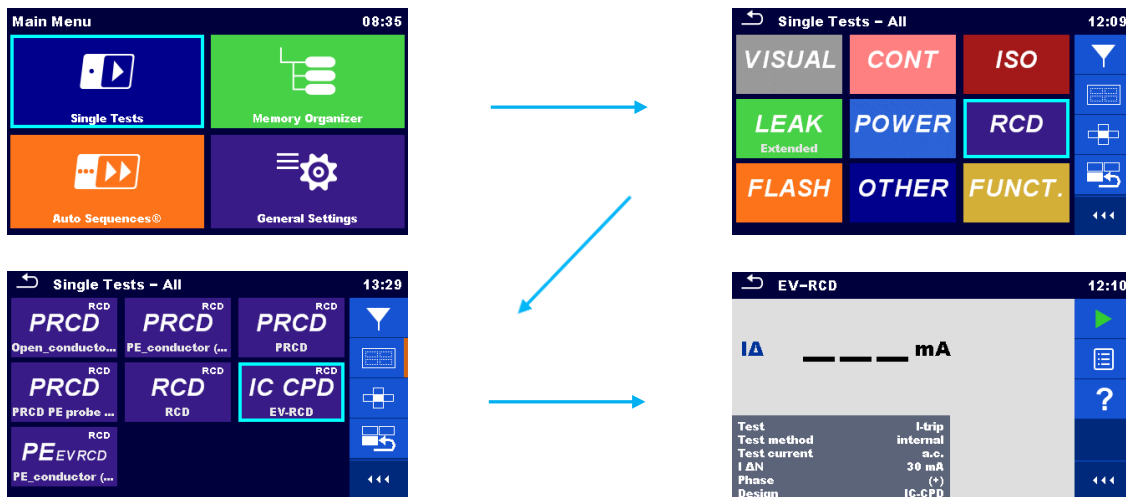

Figure 75_EV-RCD test setup

Measuring function: IC CPD / EV-RCD

Test method: internal / external

Test: t-trip / I-trip

Limit: $I\Delta N_a < I\Delta N$

Measurement procedure >> Internal <<



							
			15s		6s		15s
Switch CP STATE	Status	Status	Switch CP STATE	Status	Switch CP STATE	Status	Switch CP STATE
A 1532	MI 3365	MI 3365	A 1532	MI 3365	A 1532	MI 3365	A 1532
Not connected Status A	Start test 	Turn on equipment. Set device from state A to state C.	Charging Status C	Set device to state A. Note: for some devices not needed.	Not connected Status A	Turn on equipment. Set device from state A to state C.	Charging Status C
Set switch CP state to Status A. Proceed to next step.							

Table 34_EV-RCD test procedure

Notes!

- Repeat test procedure for different, EV-RCD settings.
- Some IC CPD's have auto-restart function, for such devices steps 6 & 7 can be skipped.

Proximity Pilot resistor check (Optional)

Scope of test:

Charging speed is determined through the Proximity Pilot (PP). The PP is a resistor connected between the PP pin and the PE pin on the Type 2 connector or socket of a Mode 2 EV cable, a Mode 3 EVSE charging station or the EV. The coding of the resistor actually determines what cable is being used (the cross section) which further determines the maximum charging current and consequently charging speed.

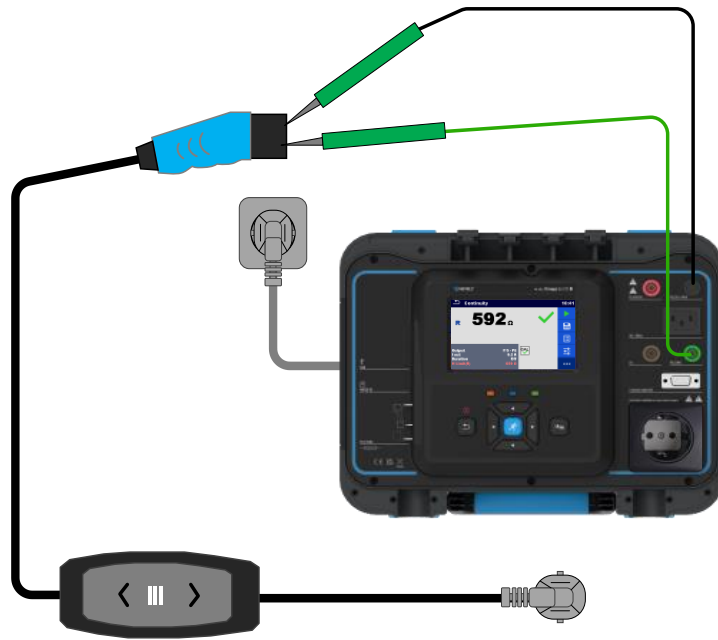

Figure 76_PP resistor_Test

Test lead	EV Cable	MI 3365
Black	PP-pin	P/S
Green	PE-pin	PE

Table 35_Test leads setup

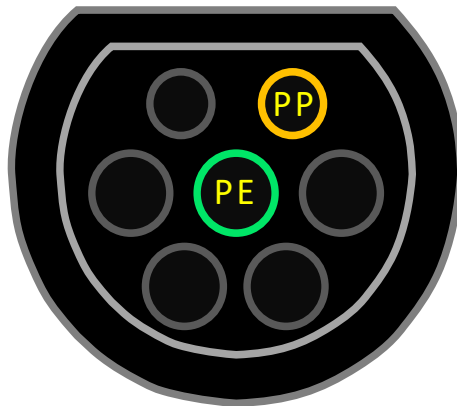
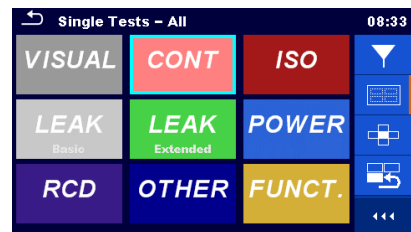
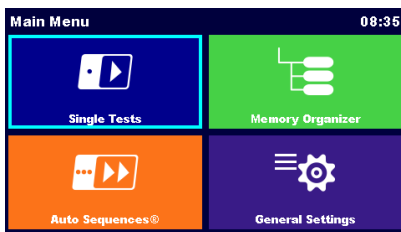

Figure 77_Position of the PE & PP pins on the mode 2 EV cable



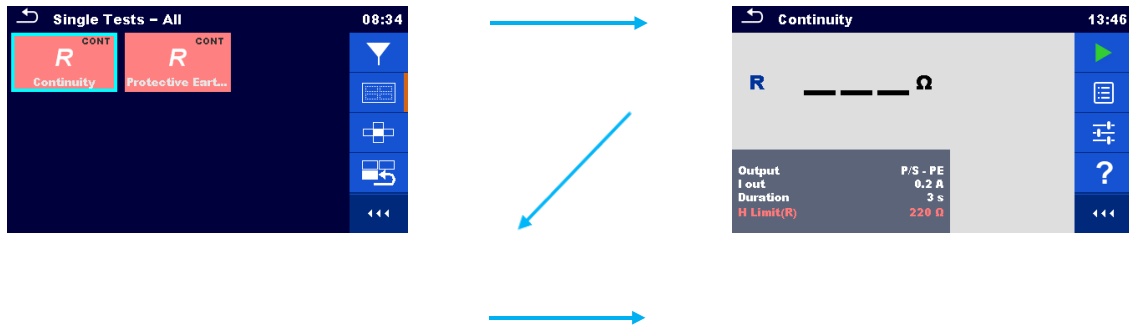

Figure 78_Resistance measurement setup

Measuring function: R Continuity / Continuity

Output parameter: P/S – PE

Iout: 0.2 A

Limits: The PP resistor can have the following values according to EN 61851-1:

- 1500 Ω \rightarrow 13 A Charging cable
- 680 Ω \rightarrow 20 A Charging cable
- 220 Ω \rightarrow 32 A Charging cable
- 100 Ω \rightarrow 63 A Charging cable

Error test

Scope of test:

Error test help assess the overall condition and functionality of the Mode 2 EV cable and diagnose the state of the Mode 2 cable protective circuit to react to possible errors present on the input and output side of the cable.

By simulating errors at the Mode 2 cable output, we ensure that in the event of a malfunction on the EV vehicle, the dangerous mains voltage is switched off at the cable output.

By identifying these faults, you can take appropriate measures to repair or replace the cable, ensuring safe and reliable EV charging.

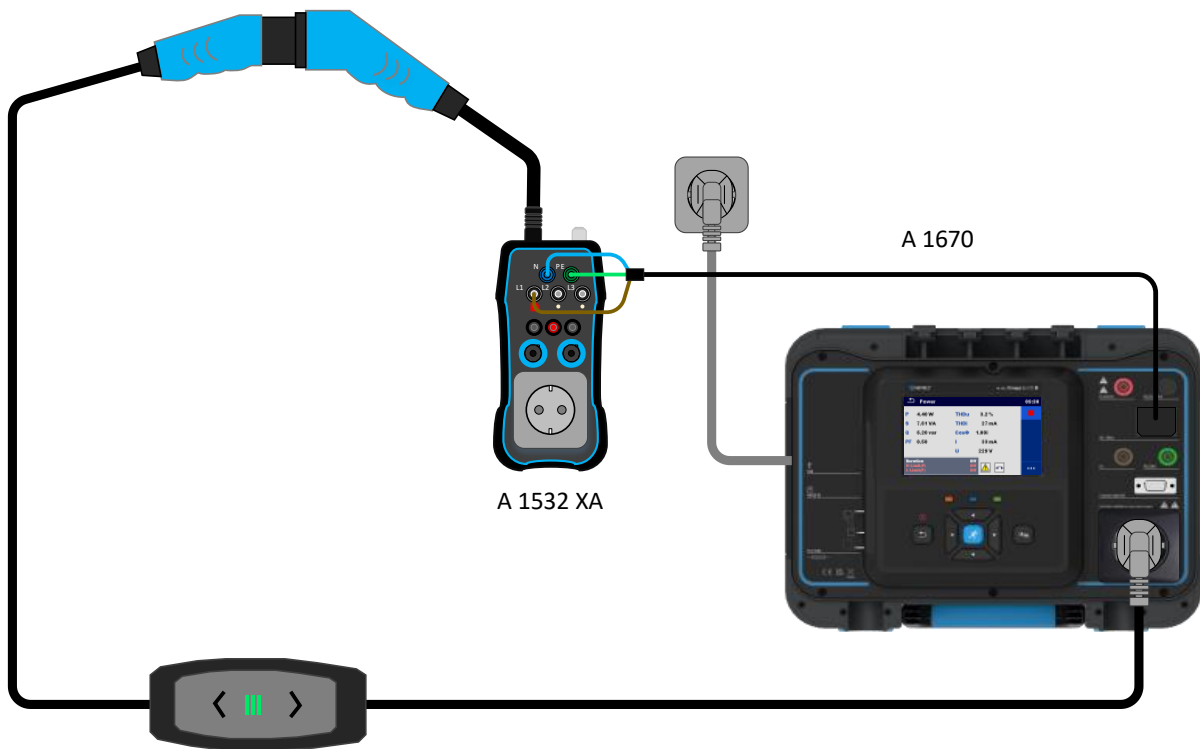
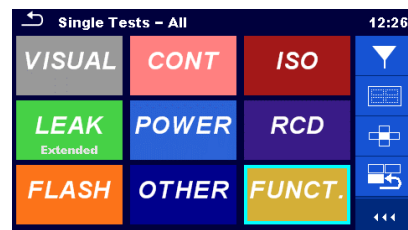
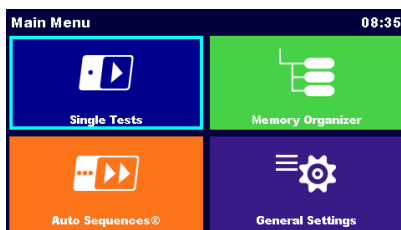

Figure 79_Error test



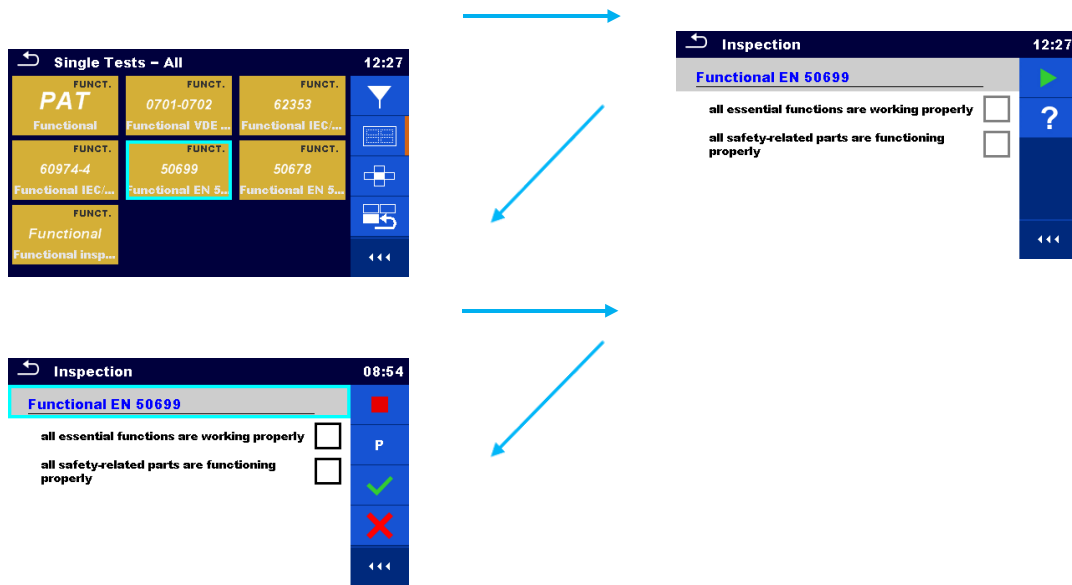

Figure 80_Functional inspection setup

Measurement procedure

Connect the charging cable between the MI 3365 and the A 1532 (see Figure 56_Mode 2 cable connection).

While the EVSE is in state C or D press and hold any of the fault simulation push buttons for at least 3 s and check the response of the EVSE, follow the steps from bellow table.

Check the response of the tested charging cable.

Step	MI 3365	Switch CP STATE	ERRORS Button	Switch Error ON	Test condition
1.	Power test = On	Charging Status C	OUTPUT P ^E op	Error ON/OFF = On Hold for 3s	PE opened, EVSE output should de-energize within 100 ms. Observe manufacturer information for proper operation.
Turn off the Power test, set switch CP state to Status A. Proceed to next step.					
2.	Power test = On	Charging Status C	OUTPUT CPsh	Error ON/OFF = On Hold for 3s	CP - PE shorted, EVSE output should de-energize within 3 s. Observe manufacturer information for proper operation
Turn off the Power test, set switch CP state to Status A. Proceed to next step.					
* 3.	Power test = On	Charging Status C	OUTPUT →sh	Error ON/OFF = On	CP diode shorted,

				Hold for 3s	EVSE output should de-energize within 3 s. Observe manufacturer information for proper operation
Turn off the Power test, set switch CP state to Status A. Proceed to next step. Error test finished.					

Table 36_Applicable error test

*CP diode shorted test can be performed optionally.

3. Mode 3 EV cables testing using A 1832

The A 1832 is intended for testing Mode 3 EV charging cables with type 2 connector. Different tests can be carried out in combination with Metrel or third party safety testers.

Mode 3 EV Cable testing

List of Applicable test & Limits

Measurements according to German guideline for E-Mobility		
Measurement	Measuring method	Limits
Visual Inspection		
Continuity of protective conductor	Low resistance measurement	$\leq 0.3 \Omega$ (with connecting cables up to 5 m in length) plus 0.1Ω per additional 7.5 m up to max. 1.0Ω
Insulation resistance of the protective conductor to the neutral and phase conductor	Insulation resistance measurement	$\geq 1.0 \text{ M}\Omega$
Check the resistance coding for the vehicle coupling and connector according to IEC 61851-1	Resistance measurement with test device	13 A Charging cable 1500Ω 20 A Charging cable 680Ω 32 A Charging cable 220Ω 63 A Charging cable 100Ω

Table 37_Applicable measurements

Note!

Based on the experiences from the field instead of measuring the Protective conductor current, (that is already covered with the measurement of insulation resistance), it is more important to check the continuity of all relevant wires.

Visual inspection

Scope of test:

The visual inspection shall take place to detect external defects and, if possible, to determine the qualification of the suitability of the equipment for the environment.



Figure 81_Visual inspection

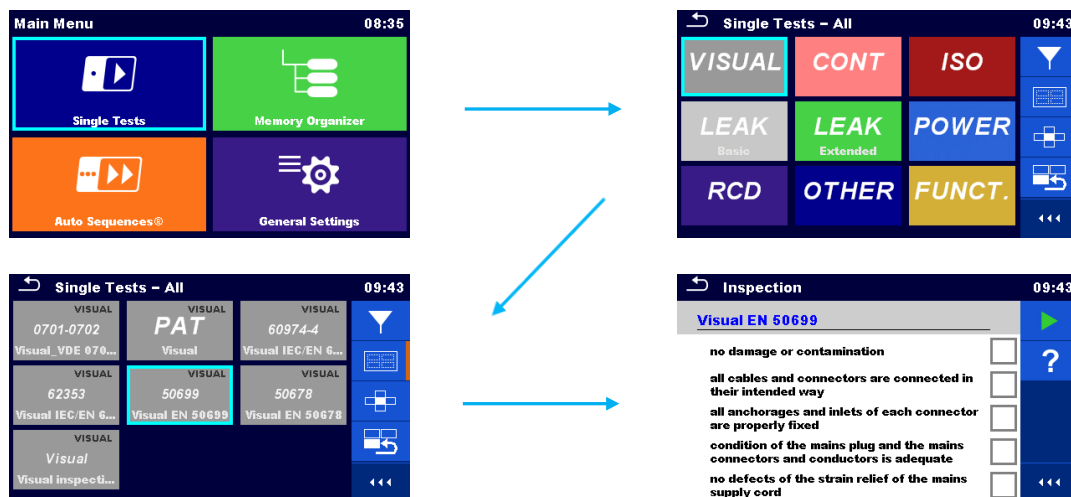

Figure 82_Visual inspection setup

Special attention shall be paid to the following:

- Check there is no damage or contamination.
- Check that connectors are connected in their intended way.
- Checking by hand to ensure that the anchorages and the inlets of each connector are properly fixed.
- Check for defects in the lead cord grip.
- Check for damage to the housing that could give access to live or dangerous parts.
- Check for signs of overload or overheating.
- Check for signs of corrosion that impact protective measures and improper ageing.
- Check for the defect due to the bending of the cord.

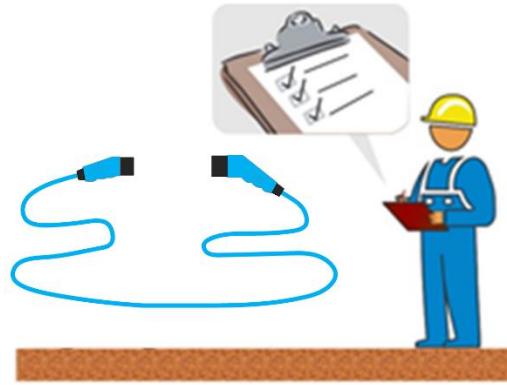

Figure 83_Visual inspection

Continuity of protective conductor

Scope of test:

With the low resistance measurement, the confirmation of the effectiveness of the protective earth is evaluated.

The measurement is performed using the MI 3365 & A 1832. The subject of evaluation is the PE conductor, between the input and the output terminal of the cable.

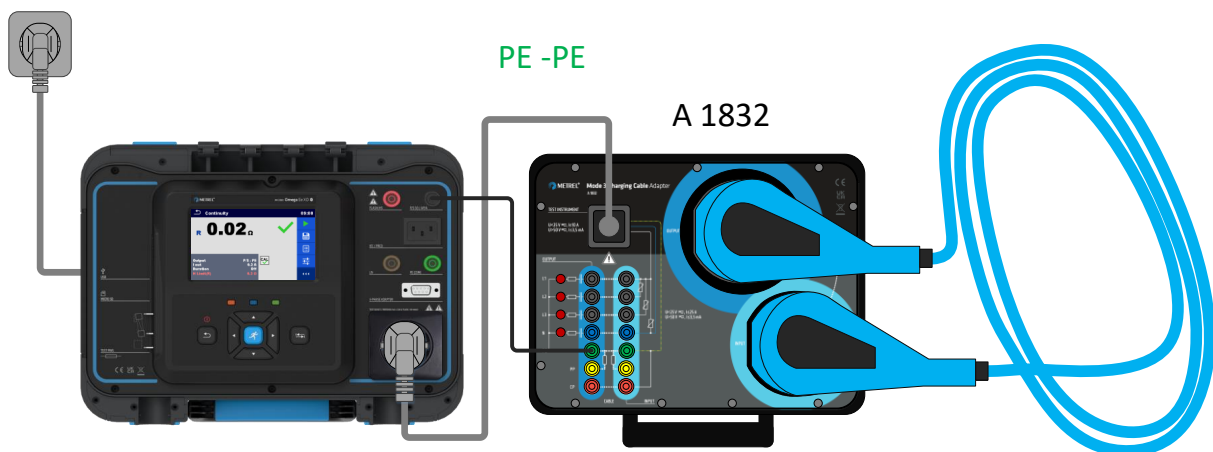

Figure 84_Continuity of protective earth

Note!

Cord must be folded during test! If the result is changing during the measurement this means that the test failed.

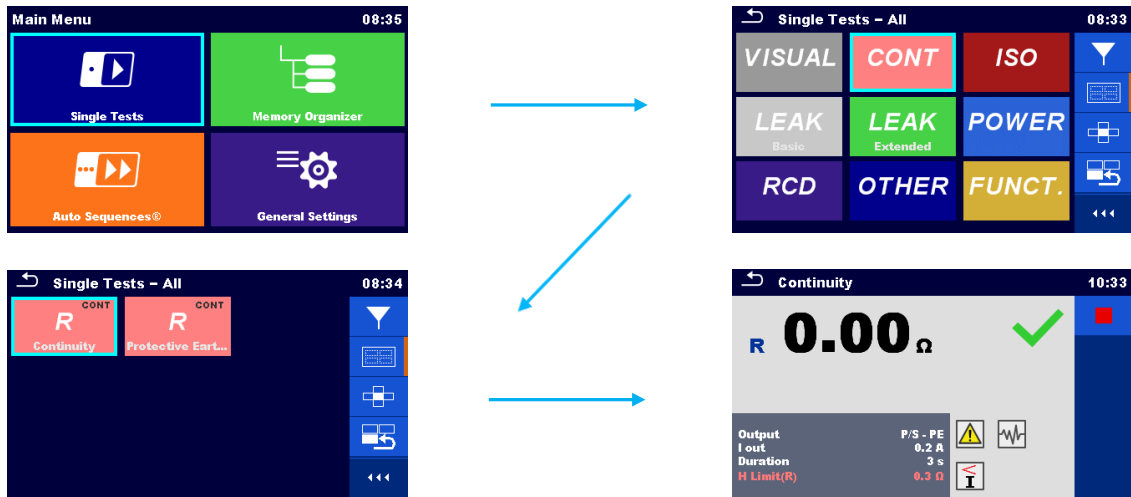

Figure 85_Earth continuity setup

Measuring function: R Continuity / Continuity

Output parameter: P/S – PE

I out: 0.2 A

Limit: $\leq 0.3 \Omega$ (with connecting cables up to 5 m in length) | plus 0.1Ω for each additional 7.5 m up to max. 1.0Ω

Proximity Pilot resistor check (Input and Output)

Scope of test:

Charging speed is determined through the Proximity Pilot (PP). The PP is a resistor connected between the PP pin and the PE pin on the Type 2 connector of a Mode 3 cable. The coding of the resistor actually determines what cable is being used (the cross section) which further determines the maximum charging current and consequently charging speed. The PP resistor is integrated on both ends of the cable.

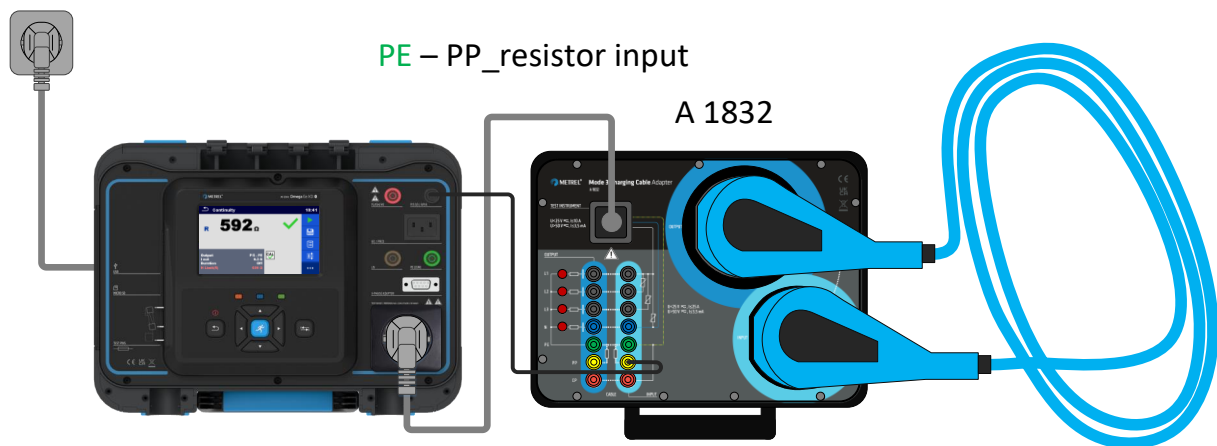

Figure 86_PP resistor_Test Input

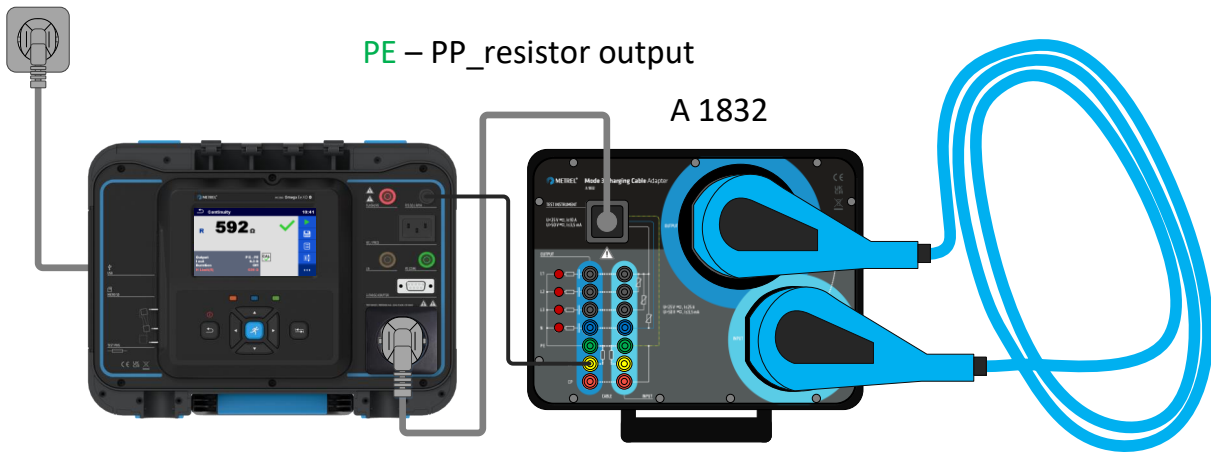

Figure 87_PP resistor_Test Output

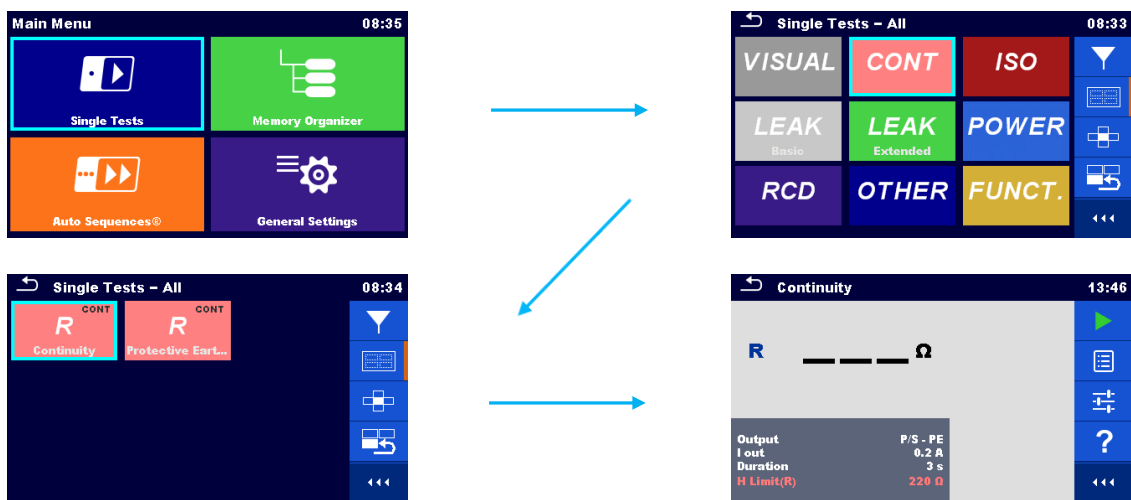

Figure 88_Resistance measurement setup

Measuring function: R Continuity / Continuity

Output parameter: P/S – PE

I_{out}: 0.2 A

Limits: The PP resistor can have the following values according to EN 61851-1:

- 1500 Ω → 13 A Charging cable
- 680 Ω → 20 A Charging cable
- 220 Ω → 32 A Charging cable
- 100 Ω → 63 A Charging cable

Continuity of CP (Control pilot) wire

Scope of test:

With the low resistance measurement, the confirmation of the effectiveness of the protective earth is evaluated.

The measurement is performed using the MI 3365 & A 1832. The subject of evaluation is the PE conductor, between the input and the output terminal of the cable.

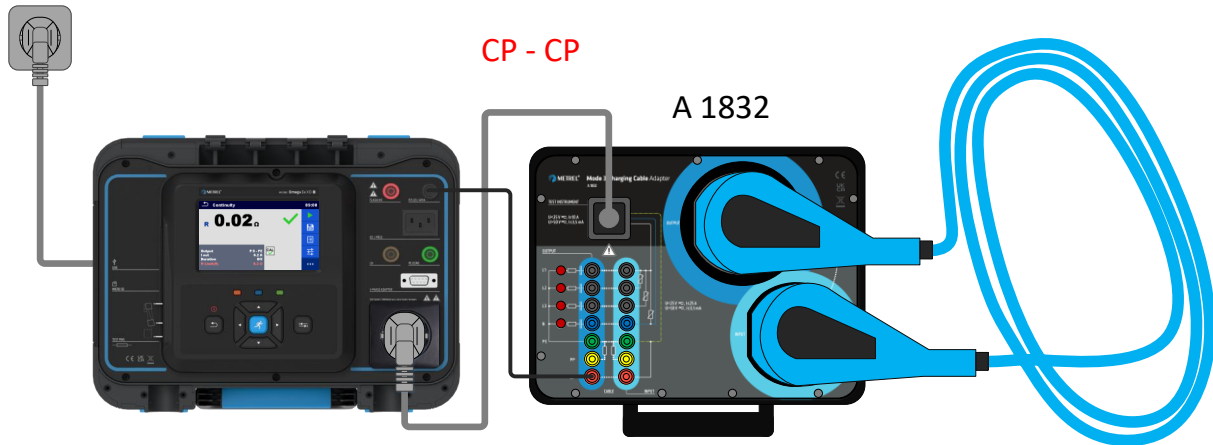

Figure 89_Continuity of Control pilot wire

Note!

Cord must be folded during test! If the result is changing during the measurement this means that the test failed.

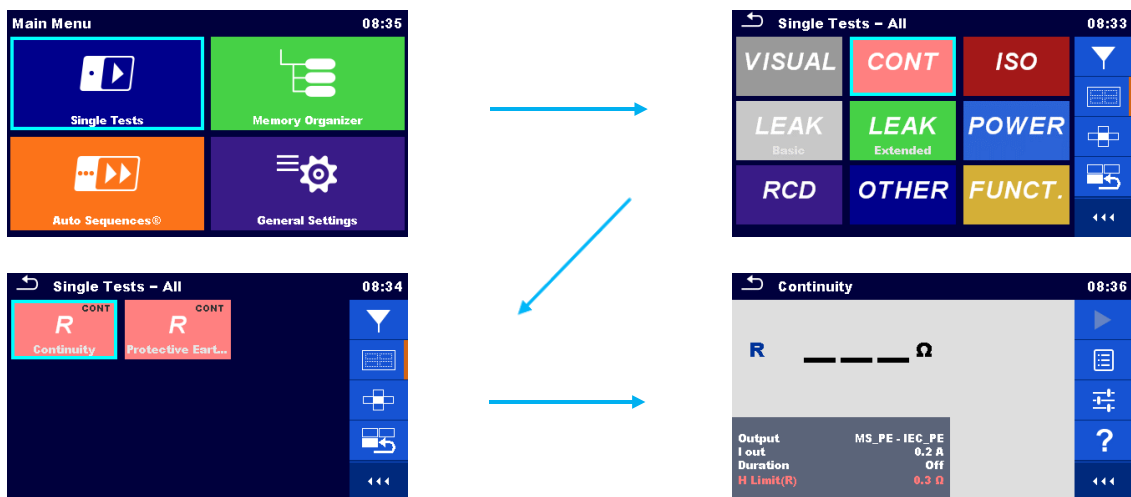

Figure 90_Earth continuity setup

Measuring function: R Continuity / Continuity

Output parameter: P/S – PE

I out: 0.2 A

Limit: ≤ 0.3 Ω (with connecting cables up to 5 m in length) | plus 0.1 Ω for each additional 7.5 m up to max. 1.0 Ω

Continuity of live wires

Scope of test:

The confirmation of the effectiveness of the live wires is evaluated.

Using the substitute leakage and the internal circuit of A 1832 it is possible to check connection of all live vires within one single test.

The measurement is performed using the MI 3365 & A 1832. The subject of evaluation are the live conductors, between the input and the output terminal of the cable.

For a positive test, all LED lamps on A 1832 shall light up.

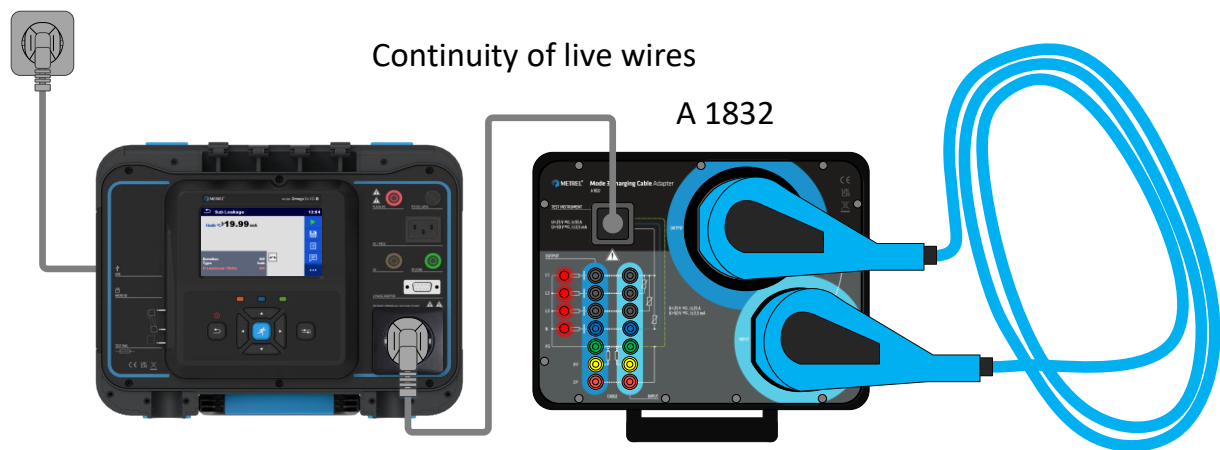

Figure 91_Continuity of live wires

Notes!

Cord must be folded during test! If the result is changing during the measurement this means that the test failed.

The measurement result on MI 3365 is irrelevant to the test itself and therefore shall not be recorded.

In case of failure, (some LED lamps on A 1832 not glowing), each wire can be evaluated separately using the Continuity function.

This is a quick continuity test of the live wires, the polarity of the wires is not detected in this test.

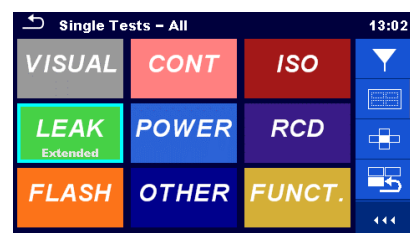
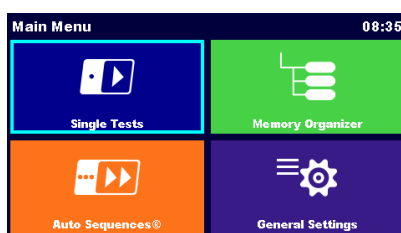

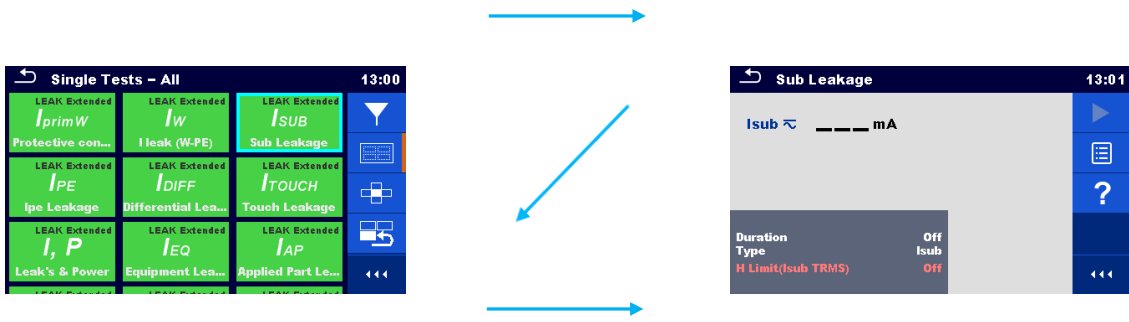

Figure 92_Earth continuity setup

Measuring function: Sub leakage

Type: Isub

Limit: All LED lamps on A 1832 shall light up

Insulation resistance of the protective conductor to the neutral and phase conductors

Scope of test:

With the insulation resistance measurement, the confirmation of the effectiveness of the insulation resistance between live wires to protective earth is evaluated. This test discloses faults caused by pollution, moisture, deterioration of insulation material etc.

The measurement is performed using the MI 3365 & A 1832. The subject of evaluation is the insulation resistance and capacitance between the PE conductor, and the live parts of the Mode 3 cable.

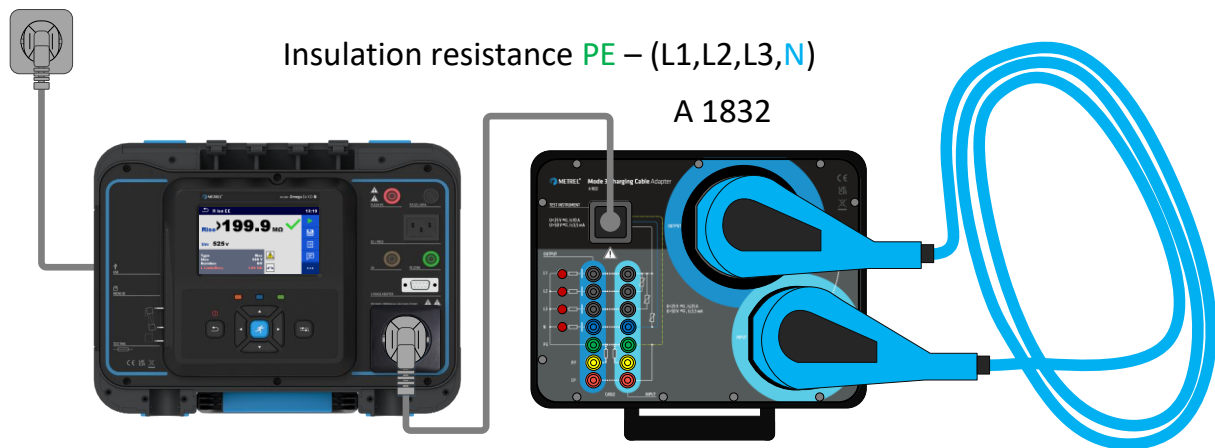

Figure 93_Insulation resistance

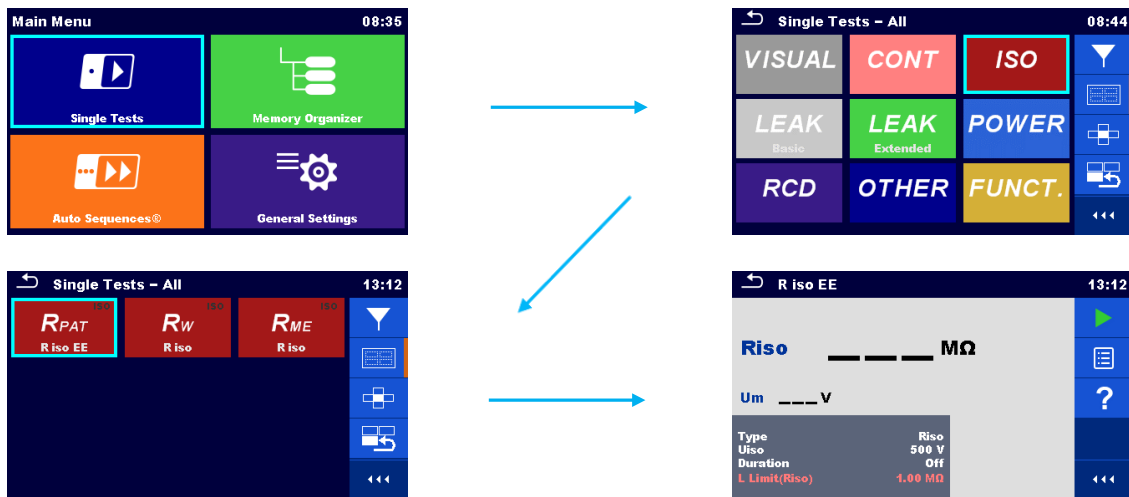

Figure 94_Insulation resistance setup

Measuring function: RPAT / Riso EE

Output parameter: Riso

Uiso: 250 V, 500 V (Observe manufacturers information for appropriate test voltage)

Limit: $\geq 1,0 \text{ M}\Omega$

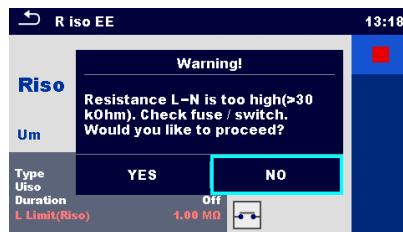

Figure 95_Insulation resistance warning

Insulation resistance pre-test is intended to warn the user for following possible causes:

- Device under test is not connected or switched on

In this application the warning message is irrelevant as the test is made on the cable without internal resistance.

Select **YES** to proceed with or **NO** to cancel measurement.

Note!

Warning message can be disabled under the settings, in the instruments setup menu! Load pretest (On/Off).

4. Testing devices with floating inputs

Electrical equipment with isolated inputs can be found, for example, in laboratories or educational institutions in the form of oscilloscopes, power analysers, bench multimeters or similar.

The main problem for the test equipment is to apply the maximum permissible nominal input voltage to the insulated input of the DUT and to determine the resulting leakage current. Typical test devices for performing tests on electrical equipment usually doesn't have suitable external voltage source available for this measurement.

The correct measurement result can also be achieved by using alternative measurement methods, the measurement procedure is described below.

General info about devices with floating inputs

Specifics that apply for this type of electrical equipment.

According to standards EN 50678 & EN 50699 at devices with floating inputs the touch current and the protective conductor current shall be measured.

Additionally, the leakage current caused by the rated input voltage on the input terminals shall be measured too.

The highest-rated input voltage is normally marked next to the measurement category (CAT) rating near the input connector. **This voltage can be much higher than 230 V.**

Typical devices which fit into this group are for example **power analysers** or **multimeters**, with a rated input voltage above 50 V AC or 120 V DC.



Figure 96_Typical devices with floating inputs

List of Applicable test & Limits

Measurements		
Measurement	Measuring method	Limits
Visual Inspection		
Continuity of protective conductor (Class I)	Low resistance measurement	$\leq 0.3 \Omega$ (with connecting cables up to 5 m in length) plus 0.1Ω per additional 7.5 m up to max. 1.0Ω
Insulation resistance of the protective conductor to the neutral and phase conductor	Insulation resistance measurement	$\geq 1.0 \text{ M}\Omega$ (secondary side)
I _{pe} + I _{fi} (Class I)	Direct, residual, alternative method	$\leq 3,5 \text{ mA}$
I _{to} + I _{fi} (Class I, Class II)	Direct, residual, alternative method	$\leq 0,5 \text{ mA}$
Functional inspection		

Table 38_Applicable measurements

Visual inspection

Scope of test:

The visual inspection shall take place to detect external defects and, if possible, to determine the qualification of the suitability of the equipment for the environment.



Figure 97_Visual inspection

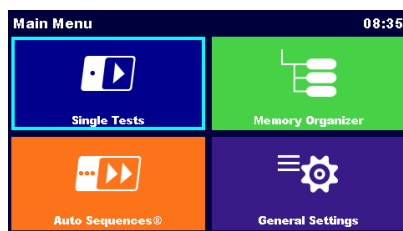

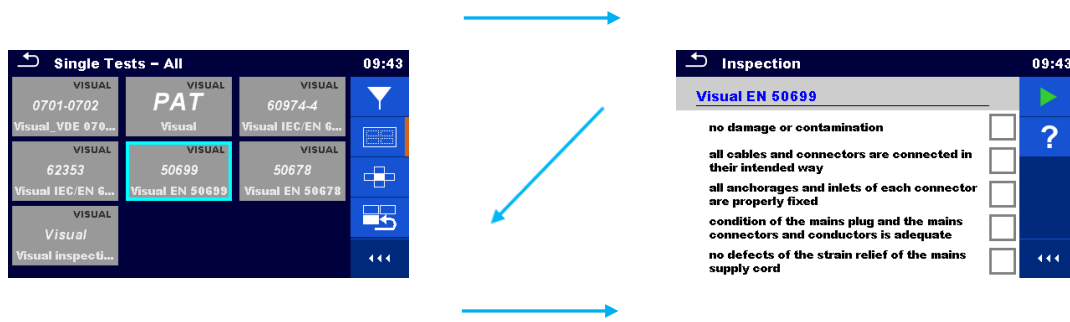

Figure 98_Visual inspection setup

Special attention shall be paid to the following:

- no damage or contamination
- all cables and connectors are connected in their intended way
- all anchorages and inlets of each connector are properly fixed
- condition of the mains plug and the mains connectors and conductors is adequate
- no defects of the strain relief of the mains supply cord
- no defect of the mains lead cord grip
- condition of the anchorage, cable clip, and accessible fuse insert is adequate
- no damage of the housing and protective cover that could give access to live or dangerous moving parts
- no signs of overload or overheating or unintended use
- no signs of an improper change
- no signs of corrosion that impacts protective measures and improper aging
- no blockage of cooling inlets and outlets e.g. air filters
- tightness of the container for water, air, or other media, and the condition of the pressure control valve is adequate
- usability of switches, control and setup equipment is adequate
- readability and completeness of all safety-relevant markings, labels, or symbols, of the ratings and of the position indicators are adequate
- all fuses accessible from the outside are complying with the data given by the manufacturer (rated current, characteristics)
- all relevant accessories together with the equipment (e.g. detachable or fixed power supply cords tubing) are assessed as adequate
- no defect due to over-bending of cords, cables, hoses, and tubing



Figure 99_Visual inspection

Continuity of protective conductor

Scope of test:

With the low resistance measurement, the confirmation of the effectiveness of the protective bonding to all accessible conductive parts connected for safety reasons to protective earth is evaluated.

The measurement is performed using the MI 3365. The subject of evaluation is the PE conductor, between the input terminal and/or all accessible earthed parts if applicable.



Figure 100_Continuity of protective earth

Note!

All relevant metal parts shall be evaluated. Check the manufacturer's information.

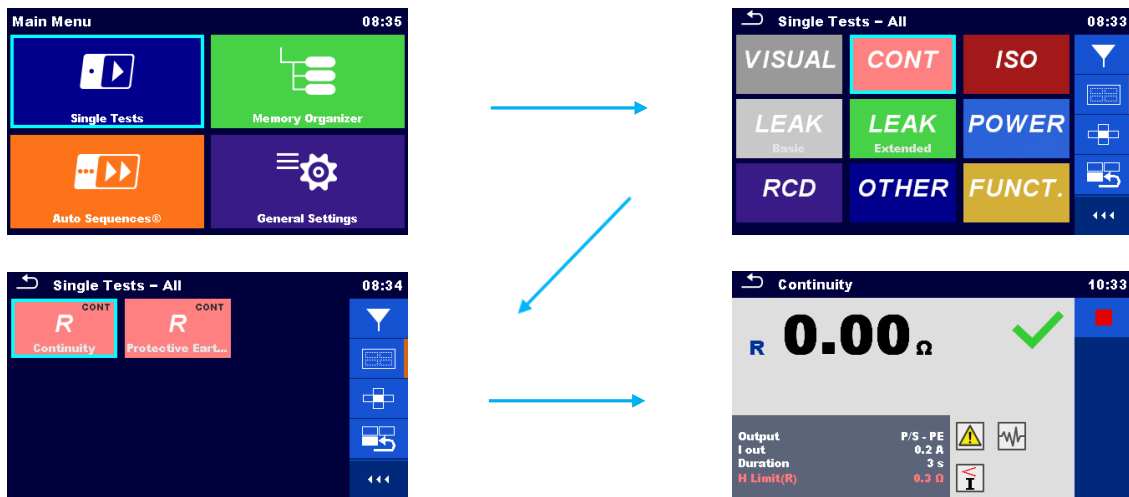

Figure 101_Earth continuity setup

Measuring function: R Continuity / Continuity

Output parameter: P/S – PE

I out: 0.2 A

Limit: $\leq 0.3 \Omega$ (with connecting cables up to 5 m in length) | plus 0.1Ω for each additional 7.5 m up to max. 1.0Ω

Measurement procedure

- Connect Electrical Equipment according to connection diagram,
- Set appropriate measurement parameters,
- Start the test.

Insulation resistance of the protective conductor to the neutral and phase conductor

Scope of test:

With the insulation resistance measurement, the confirmation of the effectiveness of the insulation resistance between live parts and accessible conductive parts (ACP) connected to protective earth is evaluated. This test discloses faults caused by pollution, moisture, deterioration of insulation material etc.

The measurement is performed using the MI 3365. The subject of evaluation is the insulation resistance between the PE conductor, and the live parts.



Figure 102_Insulation resistance Class I

Note!

If device under test has isolated metal parts these should also be evaluated.

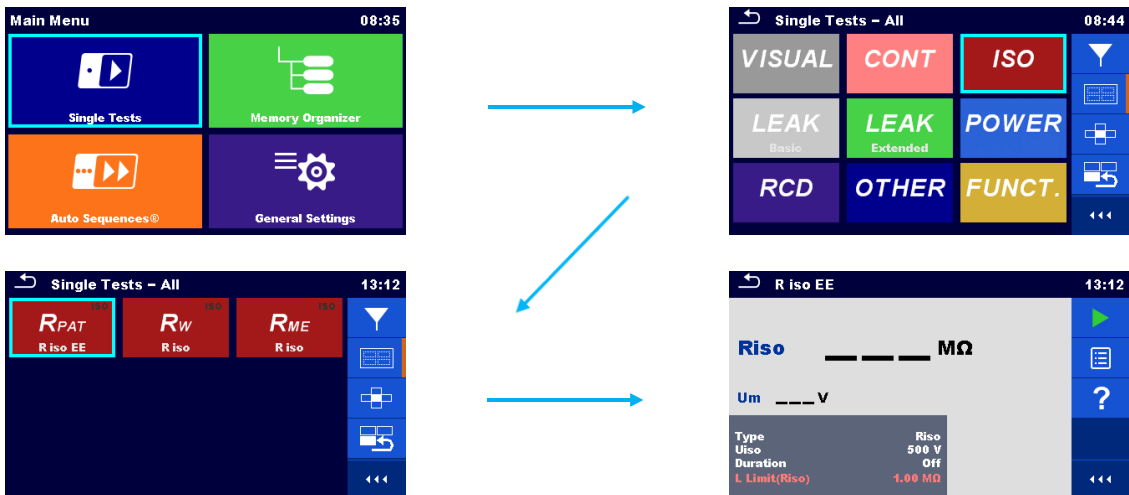

Figure 103_Insulation resistance setup

Measuring function: R_{PAT} / Riso EE (CassI), Riso-S EE (CassII),

Output parameter: Riso / Riso-S

Uiso: 250 V, 500 V (Observe manufacturers information for appropriate test voltage)

Limit: $\geq 1,0 \text{ M}\Omega$

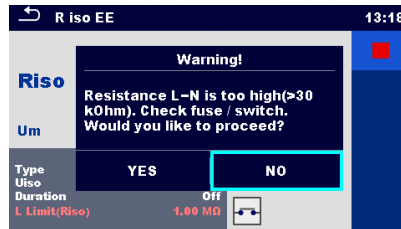

Figure 104_Insulation resistance warning

Insulation resistance pre-test is intended to warn the user for following possible causes:

- Device under test is not connected or switched on
- Input fuse of device under test is blown.

Note!

Warning message can be disabled under the settings, in the instruments setup menu! Load pretest (On/Off).

Measurement procedure

- Connect Electrical Equipment according to connection diagram,
- Set appropriate measurement parameters,
- Start the test.

Leakage current test

How to perform test on floating inputs

The standard allows two test methods:

- Test is performed with the device able to generate highest voltage, rated for the floating inputs.
 - For example, High Voltage test performed using **CE MultiTesterXA**
- In case that such voltage source is not available the measurement can be performed in 3 steps using the alternative methods.

Step 1 (Class I)

Evaluation of the Protective conductor current without connecting the inputs, (all test methods are allowed).

I_{pe} or I_{diff} is measured.

With the **PE leakage current** measurement, the subject of evaluation is the insulation resistance and capacitance between the PE conductor and the live parts of the Electrical equipment.

The PE leakage current measurement, can be performed, using two methods:

- direct method (I_{pe}),
- residual method (I_{diff}).



Figure 105_PE leakage current

Step 2 (Class I)

Evaluation of the PE leakage current caused by the voltage used by the alternative leakage method, floating inputs connected.

I_{fi} is measured.

If there are more floating inputs, individual inputs can be measured successively and the results are added together.

Using the **Alternative leakage current** measurement, the subject of evaluation is the insulation resistance and capacitance between the live parts and floating inputs of the Electrical equipment.

The leakage current shall be calculated to the highest rated voltage specified for the floating inputs.



Figure 106_Ifi_Alternative method Class I

Step 3 (Class I)

The total protective conductor current / touch-current evaluated by addition of the leakage current in step 1) and step 2).

The end result Ipe + Ifi or Idiff + Ifi is calculated as sum of Ipe or Idiff current and Ifi (the overall value).

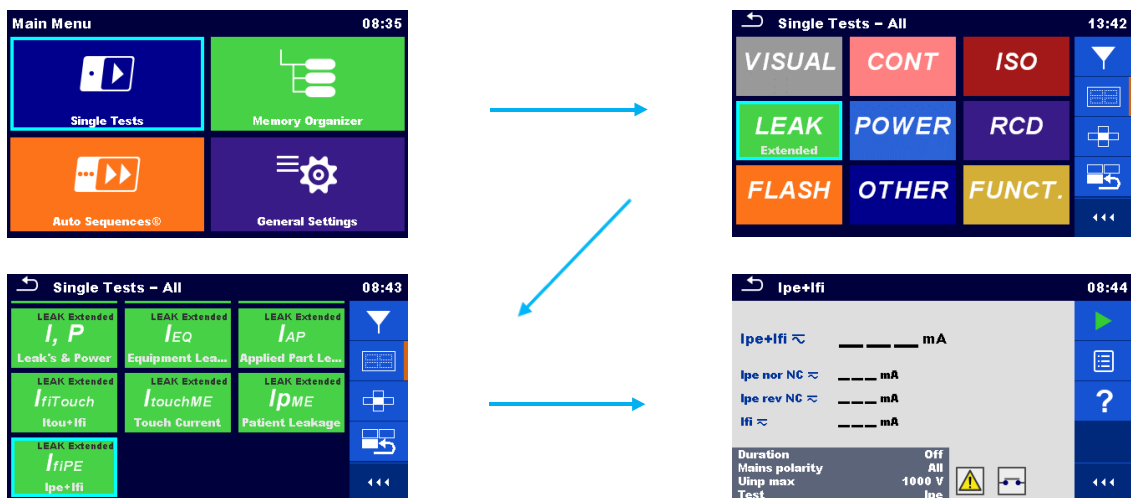

Figure 107_Ipe+Ifi setup Class I

Measuring function: Ifipe Leakage (PE leakage, direct/residual)

Test: PE leakage + Floating input leakage

Limit: ≤ 3,5 mA

Measurement procedure ClassI

Connect Electrical equipment to test instrument test socket, select the correct measuring function, and check for maximal rated input voltage specified next to floating inputs. Enter the rated voltage under parameter **Uinp max**, proceed with step 1.

After Step 1 is finished, accordingly reconnect the device under test according to step 2 and proceed measuring leakage current produced on floating inputs.

Note!

Uinp max value used for calculation of **Ifi**.

Step 1 (Class II)

Evaluation of the Touch current without connecting the inputs, (all test methods are allowed).

I_{toU} (ClassI, ClassII)

I_{toU} is measured.

With the **Touch leakage current** measurement, the subject of evaluation is the insulation resistance and capacitance between the Isolated conductive parts and the live parts of the Electrical Equipment.



Figure 108_Touch leakage current (Class II)

Step 2 (Class II)

Evaluation of the Touch leakage current caused by the voltage used by the alternative leakage method, floating inputs connected.

I_{fi} (ClassII)

I_{fi} is measured. If there are more floating inputs, individual inputs can be measured successively and the results are added together.

Using the **Alternative leakage current** measurement, the subject of evaluation is the insulation resistance and capacitance between the accessible conductive parts and floating inputs of the Electrical equipment.

The leakage current shall be calculated to the highest rated voltage specified for the floating inputs.

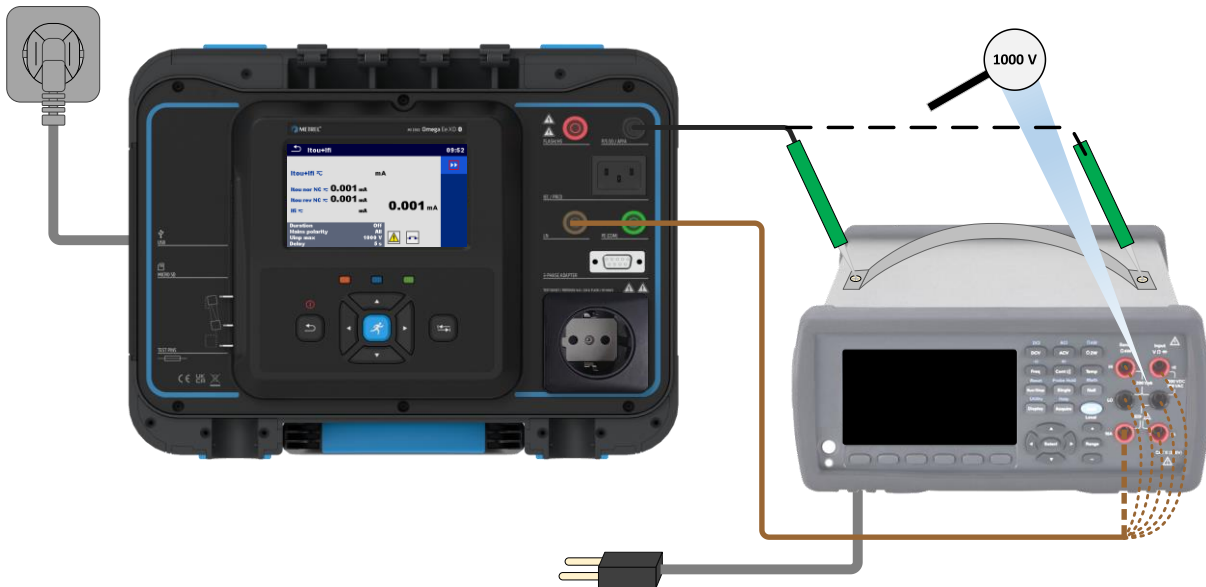

Figure 109_measurement procedure ClassII

Step 3 (Class II)

The total protective conductor current / touch-current evaluated by addition of the leakage current in step 1) and step 2).

The end result $I_{pe} + I_{fi}$ or $I_{diff} + I_{fi}$ is calculated as sum of I_{pe} or I_{diff} current and I_{fi} (the overall value).

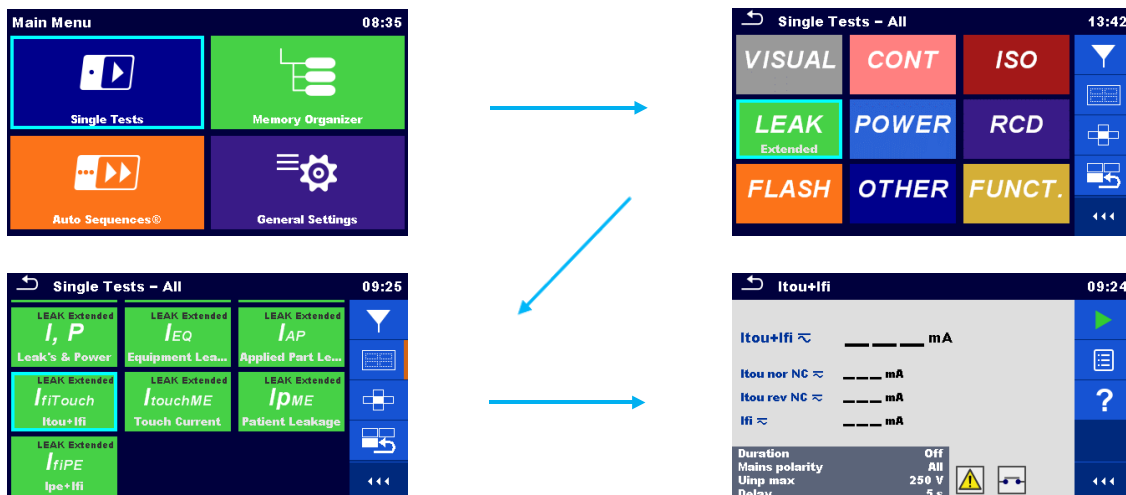

Figure 110_Itou+ Ifi setup ClassII

Measuring function: IfiTouch Leakage
Test: Touch Leakage + Floating input leakage
Limit: $\leq 0,5$ mA

Measurement procedure ClassII

Connect Electrical equipment to test instrument test socket, select the correct measuring function, and check for maximal rated input voltage specified next to floating inputs. Enter the rated voltage under parameter **Uinp max**, proceed with step 1.

Note!

Uinp max value used for calculation of Ifi.

After Step 1 is finished, accordingly reconnect the device under test according to step 2 and proceed measuring leakage current produced on floating inputs.

Functional inspection

To complete the safety test procedure, a functional test should be carried out. The manufacturer’s recommendations shall then be considered.



Figure 111_Functional inspection

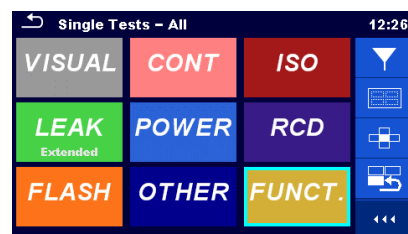
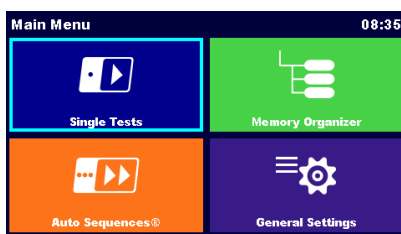

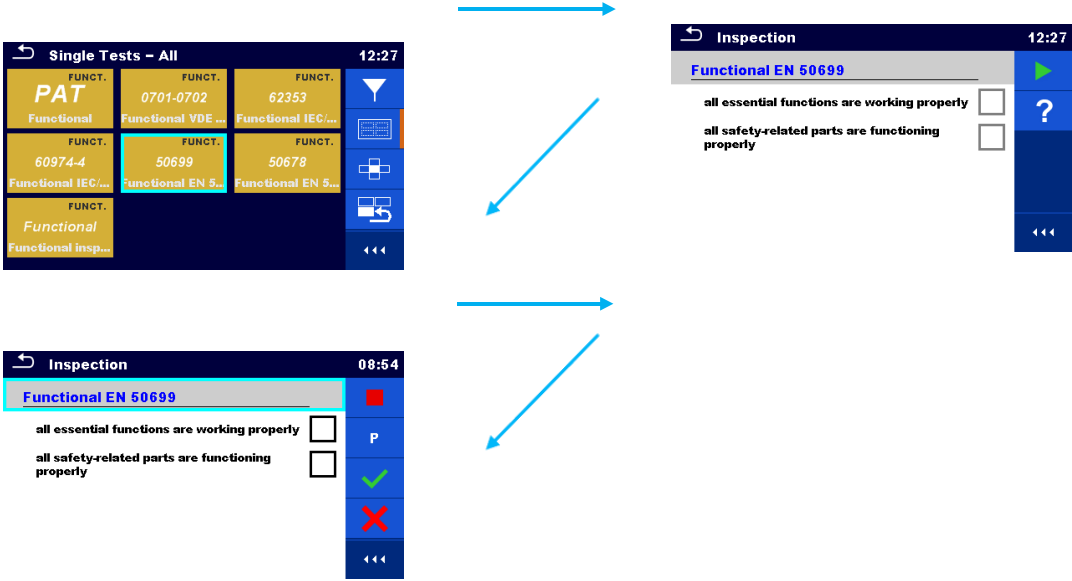

Figure 112_Functional inspection setup

Measurement procedure

Connect the Electrical equipment instrument test socket, select the correct measuring function (Functional inspection), start the test and select the correct statuses. Power can be applied to the device under test to check correct operation and consumption.